

Baxter

Welch Allyn Connex 360 Vital Signs Monitor

Software version 1.1



Instructions for use

Baxter, Connex 360, EcoCuff, SureBP, SureTemp, SureTemp Plus and Welch Allyn are trademarks of Baxter International Inc. or its subsidiaries.

Bluetooth is a trademark of Bluetooth SIG, Inc.

Durasensor, Dura-Y, Nellcor, Nellcor OxiMax Works Here logo, OxiMax, PediCheck and SatSeconds are trademarks of Nellcor Puritan Bennett LLC, d/b/a Covidien.

LNCS, Masimo, Masimo SET logo, Masimo Rainbow SET logo, Pulse CO-Oximeter, RD Set, RRP and SET are trademarks of Masimo Corporation.

Wi-Fi is a trademark of Wi-Fi Alliance.

Any other trademarks, product names or brand images appearing herein are the property of their respective owners.

This product may contain software known as "free" or "open source" software (FOSS). Baxter International Inc. uses and supports the use of FOSS. We believe that FOSS makes our products more robust and secure, and gives us and our customers greater flexibility. To learn more about FOSS that may be used in this product, please visit our FOSS website at <http://baxter.com/opensource>. Where required, a copy of FOSS source code is available.

Possession or purchase of this device does not convey any express or implied license to use this device with unauthorized sensors or cables which would, alone or in combination with this device, fall within the scope of one or more of the patents relating to this device.

Nellcor SpO2 Patient Monitoring System with OxiMax Technology and Nellcor SpO2 OxiMax Technology are trademarks of a Medtronic company.

For information about any product, contact Baxter Technical Support: [Technical Support](#).

Welch Allyn patents: <https://www.hillrom.com/patents>.

For Nellcor-equipped monitors, patents: www.covidien.com/patents.

For Masimo patents: www.masimo.com/patents.htm

This manual applies to the Connex 360 monitor  901188

 80029962F

Revision date: 2025-10



Welch Allyn, Inc.
4341 State Street Road
Skaneateles Falls, NY 13153 USA

baxter.com

The Baxter logo, featuring the word "Baxter" in a bold, blue, sans-serif font.The Masimo SET logo, featuring the word "Masimo" in a stylized font with a red circular icon to the left, and "rainbow" in a smaller font below it.

Contents

- Introduction..... 1**
 - Device description..... 1
 - Intended use/Intended purpose..... 1
 - Indications for use..... 1
 - Contraindications..... 1
 - MRI safety information..... 1
 - Related documents..... 2

- Symbols and definitions..... 3**
 - Documentation symbols..... 3
 - Power symbols..... 3
 - Connectivity symbols..... 4
 - Miscellaneous symbols..... 4
 - Mobile stand symbols..... 5

- Warnings and cautions..... 7**
 - General warnings and cautions..... 7
 - Pulse CO-Oximeter** warnings and cautions..... 11

- Controls, indicators, and connectors..... 17**

- Setup..... 21**
 - Supplies and accessories..... 21
 - Insert the battery..... 21
 - Mount the monitor onto the mobile stand..... 22
 - Connect AC power to a power source..... 23
 - Connect AC power to the wall mounted monitor..... 24
 - Connect AC power to the monitor mounted onto the mobile stand..... 24
 - Attach the probe well and temperature probe..... 26
 - Connect the NIBP hose..... 27
 - Connect the SpO2 sensor..... 27
 - Attach an accessory..... 28
 - Connect a Barcode scanner or RFID reader to a USB port..... 28

Startup.....	31
Power.....	31
Overview.....	35
Clinician Login.....	35
Common screen functionality.....	37
Primary screens.....	38
Pop-up dialogs or screens.....	42
Navigation.....	42
Patient data management.....	49
Patients tab.....	49
Home tab without Patients Tab.....	51
Loading patient data with barcode.....	52
Define or load a new patient.....	52
Manage patient records.....	52
Modifiers and manual parameters.....	53
Custom scoring (Facility Warning Score).....	57
Welch Allyn Product Configuration Tool.....	60
Advanced settings.....	60
Alarms.....	61
Vital sign summary view.....	61
Alarm system logging.....	62
Alarm limits.....	62
Alarm reminder signal.....	62
Alarm types.....	62
Alarm notification locations.....	62
Icons on the Home tab.....	63
Reset (pause or turn off) audio alarms.....	64
Adjust vital sign alarm limits.....	65
Reset alarm limits to the factory default settings.....	66
Modify audio alarm notification.....	67
Alarm messages and priorities.....	67
Nurse Call.....	68
Patient monitoring.....	69
Required parameters.....	69

Intervals.....	69
NIBP.....	74
Temperature.....	79
SpO2.....	83
RRp measurement (Respiration Rate).....	88
Maintenance and service.....	91
Perform periodic checks.....	91
Replace the monitor battery.....	91
Clean and disinfect the equipment.....	93
Prepare the device for cleaning and disinfection.....	94
Step 1: Cleaning.....	95
Step 2: Disinfection.....	95
Approved cleaning and disinfecting agents.....	95
Remove liquid spills from the monitor.....	97
Store the device.....	97
Device disposal.....	97
Technical alarm and information messages.....	99
NIBP messages.....	99
SpO2 messages.....	106
Temperature messages.....	121
Patient and Clinician data messages.....	127
Radio messages.....	130
Connectivity messages.....	131
System messages.....	133
Software update messages.....	136
Specifications.....	137
Physical specifications.....	137
Standards and compliance.....	151
General compliance and standards.....	151
Federal Communications Commission (FCC).....	151
ISED Canada statement.....	152
EMC compliance.....	153
Electromagnetic emissions	153
Electromagnetic immunity	154

Appendix..... 159
 Approved accessories..... 159

Warranty..... 165

Introduction

This manual describes the capabilities and operation of the **Connex 360** vital signs monitor. The information, including the illustrations, pertains to a monitor configured with noninvasive blood pressure (NIBP), pulse oximetry (SpO₂), respiration rate (RESPIRATION RATE), pulse rate (PULSE RATE), and body temperature (TEMPERATURE). If your monitor configuration lacks any of these options, some information in this manual might not apply.

Before using the monitor, read the sections of the manual that pertain to your use of the monitor.

Device description

The **Connex 360** monitor provides a timely and accurate set of vital signs (in under 1 minute) to clinicians and medically qualified personnel in order to monitor patient condition.

Intended use/Intended purpose

The **Connex 360** monitor is a patient physiological monitor, designed for professional use in a clinical setting.

Indications for use

The **Connex 360** monitor is designed for use by caregivers in a clinical setting and is intended for episodic monitoring of noninvasive blood pressure, pulse rate, pulse oximetry (SpO₂), and body temperature in patients of all ages. Monitoring respiration rate from photoplethysmogram, **RRp** from Masimo, is indicated for adult and pediatric patients greater than two years old.

The most likely locations for patients to be monitored are general medical or surgical floors and general hospital and alternate care environments. This product is available for sale only upon the order of a physician or licensed health care professional.

Contraindications

This system (all configurations) is not intended to be used:

- on patients connected to heart/lung machines
- on patients being transported outside a healthcare facility
- within the controlled access area of MRI equipment
- in a hyperbaric chamber
- in the presence of flammable anesthetics

The **Connex 360** monitor is not an apnea monitor. Do not rely on the **Connex 360** monitor to detect cessation of breathing.

For a system configured with the Masimo SpO₂ module and the SpO₂ sensor **RRp** measurement option, the noninvasive measurement of Respiration Rate is not intended to be used for neonatal/infant patients.

For contraindications of accessories (ex: SpO₂ sensors), consult the accessory manufacturer's directions for use.

MRI safety information

The **Connex 360** monitor is MR unsafe.

Related documents



When using this manual, refer to the following:

- **Connex 360** Service manual with **Connex 360** Embedded Service Tool instructions: [Connex 360 monitor website](#)
- The **Connex 360** Security White Paper is available upon request. Contact your Baxter representative.
- For the MDS2 contact Baxter Technical Support: <https://www.baxter.com/contact-us/us-customer-contact-directory>
- Baxter 9600 Plus *Calibration Tester Instructions for use* <https://assets.hillrom.com/is/content/hillrom/80020333LITPDFpdf>
- Baxter website: baxter.com















Symbols and definitions

For information on the origin of these symbols, see the symbols glossary: welchallyn.com/symbolsglossary.





Documentation symbols

	WARNING	The warning statements in this manual identify conditions or practice that could lead to illness, injury, or death.
	CAUTION	The caution statements in this manual identify conditions or practices that could result in damage to the equipment or other property, or loss of data. This definition applies to both yellow and black and white symbols.
		Follow the instructions for use (IFU) -- mandatory action. A copy of the IFU is available on this website. A printed copy of the IFU can be ordered from Baxter for delivery within 7 days.













Power symbols









	Stand-by		Equipotentiality
	Monitor is plugged into Alternating Current power		Battery absent or faulty
	Alternating Current power present, battery fully charged		Battery charge level
	Alternating Current power present, battery is charging		Battery cover
	Alternating Current (AC)		Rechargeable battery
	Rated power input, DC		AC input power
Li-ion	Lithium-ion battery		Direct current (DC)
	Protective Earth (PE)		

Connectivity symbols



	USB		Nurse call
	<p>Wireless signal strength</p> <ul style="list-style-type: none"> • Best (4 bars) • Good (3 bars) • Fair (2 bars) • Weak (1 bar) • No signal (no bars) • No connection (icon very dim) • Connection error (X in corner over bars) 		Ethernet RJ-45

Miscellaneous symbols

	Manufacturer		Defibrillation-proof Type BF applied parts
	Product Identifier		Serial Number
	Reorder number		
	Do not reuse		Prescription only or "For Use by or on the order of a licensed medical professional"
	Nonionizing electromagnetic radiation		Call for maintenance
	This way up		Fragile; handle with care
IP22	<p>IP = International Protection Marking</p> <p>First characteristic numeral 2 = Protected against solid objects >12.5mm in diameter.</p> <p>Second characteristic numeral 2 = Protected against vertically falling water drops when enclosure tilted up to 15°</p>		
	Temperature limit		Global Trade Item Number

	Stacking limit by number		Keep dry
	Humidity limitation		Recycle
	Medical Device		Atmospheric pressure limitation
	Separate collection of Electrical and Electronic Equipment		MR Unsafe items should not enter the MRI scanner room. Patients with MR Unsafe devices should not be scanned.

Mobile stand symbols

	Maximum safe working load limits		Mass in kilograms (kg)
	The caution statements in this manual identify conditions or practices that could result in damage to the equipment or other property, or loss of data. This definition applies to both yellow and black and white symbols.		

Warnings and cautions

Warning and caution statements can appear on the monitor, on the packaging, on the shipping container, or in this document.

The monitor is safe for patients and clinicians when used in accordance with the instructions and the warning and caution statements presented in this manual.

Before using the monitor, familiarize yourself with the sections of these Instructions for use that pertain to your use of the monitor.



WARNING The warning statements in this manual identify conditions or practices that could lead to illness, injury, or death.



CAUTION The caution statements in this manual identify conditions or practices that could result in damage to the equipment or other property, or loss of patient data.

General warnings and cautions



WARNING Patient injury risk. Many environmental variables, including patient physiology and clinical application, can affect the accuracy and performance of the monitor. Therefore, you must verify all vital signs information before treating the patient. If there is any question about the accuracy of a measurement, verify the measurement using another clinically accepted method.



WARNING Personal injury risk. The power cord is the disconnect device to isolate this equipment from supply mains. Position the equipment so that it is not difficult to reach or disconnect the cord.



WARNING Patient injury risk. Damaged cords, cables, and accessories can affect patient and operator safety. Never lift the monitor by the power supply cord or patient connections. Routinely inspect the AC power cord, blood pressure cuff, SpO2 cable, and other accessories for strain relief wear, fraying, or other damage. Replace as necessary.



WARNING Patient injury risk. During defibrillation, keep discharge paddles away from monitor sensors and other conductive parts in contact with the patient.



WARNING Patient injury risk. Use only accessories approved by Baxter including electrodes, lead wires, and patient cables. These approved accessories are required for electrical protection of the patient during cardiac defibrillation.



WARNING Patient injury risk. Do not place the monitor or any accessories in any position that might cause them to fall on the patient.



WARNING Patient injury risk. If you use Stat mode repeatedly, periodically observe the patient's limb to ensure that circulation is not impaired and that the cuff remains in place. Prolonged impairment of circulation or improper cuff position can cause bruising.



WARNING Patient injury risk. Do not place the cuff on the arm on the same side of a mastectomy. If necessary, use the femoral artery in the thigh to take a measurement.



WARNING Do not apply cuff to areas on patient where skin is delicate or damaged. Check cuff site frequently for irritation.

















WARNING Equipment failure and patient injury risk. Do not cover the air intake or exhaust vents on the rear and base of the monitor. Covering these vents could cause overheating of the monitor or muffling of alarms.



WARNING For operator and patient safety, peripheral equipment and accessories that can come in direct patient contact must comply with all applicable safety, EMC, and regulatory requirements.

Warnings and cautions

-  **WARNING** Equipment damage and personal injury risk. No modifications to the monitor are allowed by anyone other than a qualified service representative. Modification of the monitor could be hazardous to patients and personnel.
-  **WARNING** Fire and explosion hazard. Do not operate the monitor or accessories in the presence of a flammable anesthetic mixture with air, oxygen, or nitrous oxide; in oxygen-enriched environments; or in any other potentially explosive environment.
-  **WARNING** Fire and shock hazard. Only connect Local Area Network (LAN) cables used for communication contained within the perimeter of a single building. Conductive LAN cables spanning multiple buildings may introduce fire or shock hazards unless they are fitted with fiber optic cables, lightning arresters, or other applicable safety features.
-  **WARNING** Electric shock hazard. This equipment must only be connected to a supply mains with protective earth.
-  **WARNING** Electric shock hazard. Do not open the monitor or attempt repairs. The monitor has no user-serviceable internal parts. Only perform routine cleaning and maintenance procedures specifically described in this manual. Inspection and servicing of internal parts shall only be performed by qualified service personnel.
-  **WARNING** Electric shock hazard. All signal input and output (I/O) connectors are intended for connection of only devices complying with IEC 60601-1, or other IEC standards (for example, IEC 60950), as applicable to the monitor. Connecting additional devices to the monitor may increase chassis or patient leakage currents. To maintain operator and patient safety, consider the requirements of IEC 60601-1. Measure the leakage currents to confirm that no electric shock hazard exists.
-  **WARNING** Explosion or contamination hazard. Improper disposal of batteries may create an explosion or contamination hazard. Never dispose of batteries in refuse containers. Always recycle batteries according to local regulations.
-  **WARNING** Alarm limits are patient- or facility-specific. The clinician must set or verify alarm limits appropriate for each patient. Each time the monitor is powered on, you must check that the alarm settings are appropriate for your patient before you start monitoring.
-  **WARNING** Inaccurate measurement risk. The monitor is not intended for use during patient transport outside of the medical facility. Do not use the monitor to take measurements on any patient in transit.
-  **WARNING** Inaccurate measurement risk. Do not connect more than one patient to a monitor.
-  **WARNING** Inaccurate measurement risk. Dust and particle ingress can affect the accuracy of blood pressure measurements. Use the monitor in clean environments to ensure measurement accuracy. If you notice dust or lint build-up on the monitor's vent openings, have the monitor inspected and cleaned by a qualified service technician.
-  **WARNING** Inaccurate measurement risk. Do not expose to temperatures higher than 122 °F (50 °C).
-  **WARNING** Inaccurate measurement risk. Do not use the monitor on patients who are on heart-lung machines.
-  **WARNING** Inaccurate measurement risk. Do not use the monitor on patients who are experiencing convulsions or tremors.
-  **WARNING** Liquids can damage electronics inside the monitor. Prevent liquids from spilling on the monitor.

If liquids are spilled on the monitor:

1. Power down the monitor.
2. Disconnect the power plug.

3. Remove battery pack from the monitor.
4. Dry off excess liquid from the monitor.



NOTE If liquids possibly entered the monitor, remove the monitor from use until it has been properly dried, inspected, and tested by qualified service personnel.

5. Reinstall battery pack.
6. Reconnect the power plug.
7. Power on the monitor and verify that the monitor functions normally before using it.



WARNING If there is ingress, the device may not work and will trigger a technical alarm.



WARNING Defective batteries can damage the monitor. If the battery shows any signs of damage or cracking, it must be replaced immediately and only with an approved battery.



WARNING Personal injury risk. Improper handling of the battery can lead to heat generation, smoke, explosion or fire. Do not short-circuit, crush, incinerate, disassemble the battery, or use an unapproved battery pack. Never dispose of batteries in refuse containers. Always recycle batteries according to national or local regulations.



WARNING Use only approved accessories, and use them according to the manufacturer's instructions for use. Using unapproved accessories with the monitor can affect patient and operator safety and can compromise product performance and accuracy, and void the product warranty.



WARNING Wall mounted equipment and accessories must be installed in accordance with accompanying instructions. Baxter is not responsible for the integrity of any installation not performed by authorized Baxter service personnel. Contact an authorized service representative or other qualified service personnel to ensure professional installation for safety and reliability of any mounting accessory.



WARNING Baxter is not responsible for the integrity of a facility's power. If the integrity of a facility's power or protective earth conductor is in doubt, always operate the monitor on battery power alone when it is attached to a patient.



WARNING Patient injury risk. As with all medical equipment, carefully route patient cabling to reduce the possibility of patient entanglement or strangulation.



WARNING Inaccurate measurement risk. Do not use the monitor or accessories during magnetic resonance imaging (MRI) or in an MRI environment.



WARNING To protect against injury, follow the directions below:

- Avoid placing the device and accessories on surfaces with visible liquid spills.
- Do not soak or immerse the device or accessories in liquids.
- Use cleaning solutions only as instructed in this manual or in appropriate accessory's manual.
- Do not attempt to clean the device or accessories while monitoring a patient.



WARNING Electric shock hazard. To protect from electric shock, always remove and completely disconnect any accessories, including sensors, before bathing the patient.



WARNING Maintain minimum separation distance of 12 inches (30 cm) between any part of the monitor and portable RF communication equipment (including peripherals such as antenna cables and external antennas). Performance of the monitor might degrade if proper distance is not maintained.



WARNING Electromagnetic interference risk. The monitor complies with applicable domestic and international standards for electromagnetic interference. These standards are intended to minimize medical equipment electromagnetic interference. Although this monitor is not expected to present problems to other compliant equipment or be affected by other compliant devices, interference issues still may occur. As a precaution, avoid using the monitor in close proximity to other equipment. In the event that equipment interference is observed, relocate the equipment as necessary or consult manufacturer's instructions for use.



WARNING Do not use a long press of  to power down the monitor when it is functioning normally. You will lose patient data and configuration settings.



WARNING Do not use NIBP or other constricting instruments on the same appendage as the sensor.



WARNING Do not simultaneously be in contact with device connectors and patient.



CAUTION Product security hazard. Protect your passwords and physical access to computers and servers with the **Connex 360** monitor. Follow local and facility-wide practices and regulations intended to protect patient data. Unauthorized access can lead to loss of data confidentiality, corruption of data, device unavailability, and attempts to retrieve customer network credentials from the **Connex 360** monitor.



CAUTION Patient injury risk. To ensure data integrity and patient confidentiality, save readings and clear the monitor's display between patients.



CAUTION Patient injury risk. Any external compression of the blood pressure hose or cuff may cause patient injury, system errors, or inaccurate measurements.



CAUTION Patient injury risk. Verify patient identity on the monitor after manual or barcode entry and before printing or transferring patient records. Failure to identify the correct patient can result in patient injury.



CAUTION Inaccurate measurement risk. Do not place the cuff where it can disturb proper circulation. Do not place the cuff on any area where circulation is compromised or on any extremity used for intravenous infusions. Do not use an SpO2 sensor and a blood pressure cuff simultaneously on the same limb. Doing so may cause a temporary loss of pulsatile flow, resulting in either no reading or an inaccurate SpO2 or pulse rate until the flow returns.



CAUTION Equipment damage and personal injury risk. When transporting the monitor on a mobile stand, properly secure all patient cables and cords to keep them clear of the wheels and to minimize trip hazards.



CAUTION The monitor may not function properly if dropped or damaged. Protect it from severe impact and shock. Do not use the monitor if you notice any signs of damage. Qualified service personnel must check any monitor that is dropped or damaged for proper operation before putting the monitor back into use.



CAUTION To ensure safety, avoid stacking multiple devices or placing anything on the device or accessories during operation.



CAUTION United States Federal law restricts this monitor to sale, distribution, or use by or on the order of a physician or licensed healthcare professional.





CAUTION Do not sterilize the monitor. Sterilizing the monitor could harm the device. Refer to cleaning and disinfecting instructions.









CAUTION Never move the monitor or mobile stand by pulling on any of the cords. This may cause the monitor to tip over or damage the cord. Never pull on the power cord when disconnecting the cord from the mains outlet. When disconnecting the power cord, always grasp the attachment plug. Keep the cord away from liquids, heat, and sharp edges. Replace the power cord if the strain relief, cord insulation, or metal prongs are damaged or begin to separate from the attachment plug.



CAUTION Do not exceed the maximum weight limits for your mobile stand with bins. See the "Specifications" section for the bin and mobile stand maximum weight limits.

-  **CAUTION** Use only the approved USB client cable to connect a laptop computer to the USB client port. Any laptop connected to the monitor must be running on a battery, a 60601-1 compliant power supply, or a 60601-1 compliant isolation transformer.
-  **CAUTION** If the touchscreen is not responding properly, refer to the troubleshooting section. If the problem cannot be resolved, discontinue use of the monitor and contact an authorized service center or qualified service personnel.
-  **CAUTION** Disposal of product - Comply with local laws in the disposal of the device and/or its accessories.

Pulse CO-Oximeter warnings and cautions

-  **WARNING** Patient injury risk. Do not start or operate the **Pulse CO-Oximeter** unless the setup was verified to be correct.
-  **WARNING** Do not use the **Pulse CO-Oximeter** if it appears or is suspected to be damaged.
-  **WARNING** Patient injury risk. If any measurement seems questionable, first check the patient's vital signs by alternate means and then check the **Pulse CO-Oximeter** for proper functioning.
-  **WARNING** Inaccurate measurement risk. Inaccurate respiration rate measurements may be caused by:
 - Improper sensor application
 - Low arterial perfusion
 - Motion artifact
 - Low arterial oxygen saturation
 - Excessive ambient or environmental noise
-  **WARNING** Inaccurate measurement risk. Inaccurate SpO2 readings may be caused by:
 - Improper sensor application and placement
 - Elevated levels of COHb or MetHb: High levels of COHb or MetHb may occur with a seemingly normal SpO2. When elevated levels of COHb or MetHb are suspected, laboratory analysis (CO-Oximetry) of a blood sample should be performed.
 - Elevated levels of bilirubin
 - Elevated levels of dyshemoglobin
 - Vasospastic disease, such as Raynaud's, and peripheral vascular disease
 - Hemoglobinopathies and synthesis disorders such as thalassemias, Hb s, Hb c, sickle cell, etc.
 - Hypocapnic or hypercapnic conditions
 - Severe anemia
 - Very low arterial perfusion
 - Extreme motion artifact
 - Abnormal venous pulsation or venous constriction
 - Severe vasoconstriction or hypothermia
 - Arterial catheters and intra-aortic balloon
 - Intravascular dyes, such as indocyanine green or methylene blue
 - Externally applied coloring and texture, such as nail polish, acrylic nails, glitter, etc.
 - Birthmark(s), tattoos, skin discolorations, moisture on skin, deformed or abnormal fingers. etc.
 - Skin color disorders
-  **WARNING** Interfering Substances: Dyes or any substance containing dyes that change usual blood pigmentation may cause erroneous readings.
-  **WARNING** The **Pulse CO-Oximeter** should not be used as the sole basis for diagnosis or therapy decisions. It must be used in conjunction with clinical signs and symptoms.



WARNING The **Pulse CO-Oximeter** is not intended to be used as the sole basis for making diagnosis or treatment decisions related to suspected carbon monoxide poisoning; it is intended to be used in conjunction with additional methods of assessing clinical signs and symptoms.



WARNING Patient injury risk. The **Pulse CO-Oximeter** is not an apnea monitor.



WARNING The **Pulse CO-Oximeter** may be used during defibrillation, but this may affect the accuracy or availability of the parameters and measurements.



WARNING The **Pulse CO-Oximeter** may be used during electrocautery, but this may affect the accuracy or availability of the parameters and measurements.



WARNING The **Pulse CO-Oximeter** should not be used for arrhythmia analysis.



WARNING SpO₂ is empirically calibrated in healthy adult volunteers with normal levels of carboxyhemoglobin (COHb) and methemoglobin (MetHb).



WARNING Do not adjust, repair, open, disassemble, or modify the **Pulse CO-Oximeter** or accessories. Injury to personnel or equipment damage could occur. Return the **Pulse CO-Oximeter** for servicing if necessary.



WARNING Do not use NIBP or other constricting instruments on the same appendage as the sensor.



WARNING High-intensity extreme lights (such as pulsating strobe lights) directed on the sensor, may not allow the **Pulse CO-Oximeter** to obtain vital sign readings.



WARNING High oxygen concentrations may predispose a premature infant to retinopathy. Therefore, the upper alarm limit for the oxygen saturation must be carefully selected in accordance with accepted clinical standards.



CAUTION Do not place the **Pulse CO-Oximeter** where the controls can be changed by the patient.



CAUTION When patients are undergoing photodynamic therapy they may be sensitive to light sources. Pulse oximetry may be used only under careful clinical supervision for short time periods to minimize interference with photodynamic therapy.



CAUTION Do not place the **Pulse CO-Oximeter** on electrical equipment that may affect the device, preventing it from working properly.



CAUTION If SpO₂ values indicate hypoxemia, a laboratory blood sample should be taken to confirm the patient's condition.



CAUTION If the Low Perfusion message is frequently displayed, find a better perfused monitoring site. In the interim, assess the patient and, if indicated, verify oxygenation status through other means.











CAUTION Change the application site or replace the sensor and/or patient cable when a "Replace sensor" and/or "Replace patient cable," or a persistent poor signal quality message (such as "Low SIQ") is displayed on the host monitor. These messages may indicate that patient monitoring time is exhausted on the patient cable or sensor.







CAUTION Inaccurate measurement risk. Do not place the cuff where it can disturb proper circulation. Do not place the cuff on any area where circulation is compromised or on any extremity used for intravenous infusions. Do not use an SpO₂ sensor and a blood pressure cuff simultaneously on the same limb. Doing so may cause a temporary loss of pulsatile flow, resulting in either no reading or an inaccurate SpO₂ or pulse rate until the flow returns.



CAUTION If using pulse oximetry during full body irradiation, keep the sensor out of the radiation field. If the sensor is exposed to the radiation, the reading might be inaccurate or the device might read zero for the duration of the active irradiation period.

-  **CAUTION** The device must be configured to match your local power line frequency to allow for the cancellation of noise introduced by fluorescent lights and other sources.
-  **CAUTION** To ensure that alarm limits are appropriate for the patient being monitored, check the limits each time the **Pulse CO-Oximeter** is used.
-  **CAUTION** Variation in hemoglobin measurements may be profound and may be affected by sampling technique as well as the patient's physiological conditions. Any results exhibiting inconsistency with the patient's clinical status should be repeated and/or supplemented with additional test data. Blood samples should be analyzed by laboratory devices prior to clinical decision making to completely understand the patient's condition.
-  **CAUTION** Do not submerge the **Pulse CO-Oximeter** in any cleaning solution or attempt to sterilize by autoclave, irradiation, steam, gas, ethylene oxide or any other method. This will seriously damage the **Pulse CO-Oximeter**.
-  **CAUTION** To minimize radio interference, other electrical equipment that emits radio frequency transmissions should not be in close proximity to the **Pulse CO-Oximeter**.
-  **CAUTION** Replace the cable or sensor when a replace sensor or when a low SIQ message is consistently displayed while monitoring consecutive patients after completing troubleshooting steps listed in this manual.
-  **NOTE** A functional tester cannot be used to assess the accuracy of the **Pulse CO-Oximeter**.
-  **NOTE** Do not loop the patient cabling into a tight coil or wrap around the device, as this can damage the patient cabling.

Masimo **Pulse CO-Oximeter** warnings, cautions, and notes

-  **WARNING** Patient injury risk. Do not start or operate the **Pulse CO-Oximeter** unless the setup was verified to be correct.
-  **WARNING** Do not use the **Pulse CO-Oximeter** if it appears or is suspected to be damaged.
-  **WARNING** Patient injury risk. If any measurement seems questionable, first check the patient's vital signs by alternate means and then check the **Pulse CO-Oximeter** for proper functioning.
-  **WARNING** Inaccurate measurement risk. Inaccurate respiration rate measurements may be caused by:
- Improper sensor application
 - Low arterial perfusion
 - Motion artifact
 - Low arterial oxygen saturation
 - Excessive ambient or environmental noise
-  **WARNING** Inaccurate measurement risk. Inaccurate SpO2 readings may be caused by:
- Improper sensor application and placement
 - Elevated levels of COHb or MetHb: High levels of COHb or MetHb may occur with a seemingly normal SpO2. When elevated levels of COHb or MetHb are suspected, laboratory analysis (CO-Oximetry) of a blood sample should be performed.
 - Elevated levels of bilirubin
 - Elevated levels of dyshemoglobin
 - Vasospastic disease, such as Raynaud's, and peripheral vascular disease
 - Hemoglobinopathies and synthesis disorders such as thalassemias, Hb s, Hb c, sickle cell, etc.
 - Hypocapnic or hypercapnic conditions
 - Severe anemia

Warnings and cautions

- Very low arterial perfusion
- Extreme motion artifact
- Abnormal venous pulsation or venous constriction
- Severe vasoconstriction or hypothermia
- Arterial catheters and intra-aortic balloon
- Intravascular dyes, such as indocyanine green or methylene blue
- Externally applied coloring and texture, such as nail polish, acrylic nails, glitter, etc.
- Birthmark(s), tattoos, skin discolorations, moisture on skin, deformed or abnormal fingers. etc.
- Skin color disorders



WARNING Interfering Substances: Dyes or any substance containing dyes that change usual blood pigmentation may cause erroneous readings.



WARNING The **Pulse CO-Oximeter** should not be used as the sole basis for diagnosis or therapy decisions. It must be used in conjunction with clinical signs and symptoms.



WARNING The **Pulse CO-Oximeter** is not intended to be used as the sole basis for making diagnosis or treatment decisions related to suspected carbon monoxide poisoning; it is intended to be used in conjunction with additional methods of assessing clinical signs and symptoms.



WARNING Patient injury risk. The **Pulse CO-Oximeter** is not an apnea monitor.



WARNING The **Pulse CO-Oximeter** may be used during defibrillation, but this may affect the accuracy or availability of the parameters and measurements.



WARNING The **Pulse CO-Oximeter** may be used during electrocautery, but this may affect the accuracy or availability of the parameters and measurements.



WARNING The **Pulse CO-Oximeter** should not be used for arrhythmia analysis.



WARNING SpO₂ is empirically calibrated in healthy adult volunteers with normal levels of carboxyhemoglobin (COHb) and methemoglobin (MetHb).



WARNING Do not adjust, repair, open, disassemble, or modify the **Pulse CO-Oximeter** or accessories. Injury to personnel or equipment damage could occur. Return the **Pulse CO-Oximeter** for servicing if necessary.



















WARNING Optical, pleth-based measurements, such as SpO₂ and **RRp** measurement, can be affected by the following:

- Improper sensor application or use of incorrect sensor.
- Blood pressure cuff applied to the same arm as the sensor site.
- Intravascular dyes such as indocyanine green or methylene blue.
- Venous congestion.
- Abnormal venous pulsations (e.g. tricuspid valve regurgitation, Trendelenburg position).
- Abnormal pulse rhythms due to physiological conditions or induced through external factors (e.g. cardiac arrhythmias, intra-aortic balloon, etc.).
- Externally applied coloring and texture such as nail polish, acrylic nails, glitter, etc.
- Moisture, birthmarks, skin discoloration, nail aberration, deformed fingers, or foreign objects in the light path.
- Elevated levels of bilirubin.
- Physiological conditions that can significantly shift the oxygen dissociation curve.
- A physiological condition that may affect vasomotor tone or changes in vasomotor tone.



WARNING High-intensity extreme lights (such as pulsating strobe lights) directed on the sensor, may not allow the **Pulse CO-Oximeter** to obtain vital sign readings.

-  **CAUTION** Do not place the **Pulse CO-Oximeter** where the controls can be changed by the patient.
-  **CAUTION** When patients are undergoing photodynamic therapy they may be sensitive to light sources. Pulse oximetry may be used only under careful clinical supervision for short time periods to minimize interference with photodynamic therapy.
-  **CAUTION** Do not place the **Pulse CO-Oximeter** on electrical equipment that may affect the device, preventing it from working properly.
-  **CAUTION** If SpO2 values indicate hypoxemia, a laboratory blood sample should be taken to confirm the patient's condition.
-  **CAUTION** If the Low Perfusion message is frequently displayed, find a better perfused monitoring site. In the interim, assess the patient and, if indicated, verify oxygenation status through other means.
-  **CAUTION** Change the application site or replace the sensor and/or patient cable when a "Replace sensor" and/or "Replace patient cable," or a persistent poor signal quality message (such as "Low SIQ") is displayed on the host monitor. These messages may indicate that patient monitoring time is exhausted on the patient cable or sensor.
-  **CAUTION** If using pulse oximetry during full body irradiation, keep the sensor out of the radiation field. If the sensor is exposed to the radiation, the reading might be inaccurate or the device might read zero for the duration of the active irradiation period.
-  **CAUTION** The device must be configured to match your local power line frequency to allow for the cancellation of noise introduced by fluorescent lights and other sources.
-  **CAUTION** To ensure that alarm limits are appropriate for the patient being monitored, check the limits each time the **Pulse CO-Oximeter** is used.
-  **CAUTION** Variation in hemoglobin measurements may be profound and may be affected by sampling technique as well as the patient's physiological conditions. Any results exhibiting inconsistency with the patient's clinical status should be repeated and/or supplemented with additional test data. Blood samples should be analyzed by laboratory devices prior to clinical decision making to completely understand the patient's condition.
-  **CAUTION** Do not submerge the **Pulse CO-Oximeter** in any cleaning solution or attempt to sterilize by autoclave, irradiation, steam, gas, ethylene oxide or any other method. This will seriously damage the **Pulse CO-Oximeter**.
-  **CAUTION** Disposal of product - Comply with local laws in the disposal of the device and/or its accessories.
-  **CAUTION** To minimize radio interference, other electrical equipment that emits radio frequency transmissions should not be in close proximity to the **Pulse CO-Oximeter**.
-  **CAUTION** Replace the cable or sensor when a replace sensor or when a low SIQ message is consistently displayed while monitoring consecutive patients after completing troubleshooting steps listed in this manual.
-  **NOTE** A functional tester cannot be used to assess the accuracy of the **Pulse CO-Oximeter**.
-  **NOTE** Do not loop the patient cabling into a tight coil or wrap around the device, as this can damage the patient cabling.
-  **NOTE** Additional information specific to the Masimo sensors compatible with the **Pulse CO-Oximeter**, including information about parameter/measurement performance during motion and low perfusion, may be found in the sensor's instructions for use (IFU).



NOTE Cables and sensors are provided with X-Cal technology to minimize the risk of inaccurate readings and unanticipated loss of patient monitoring. Refer to the Cable or Sensor IFU for the specified duration of the patient monitoring time.



NOTE Physiological conditions that result in loss of pulsatile signal may result in no SpO₂ or RRp measurement readings.

Nellcor **Pulse CO-Oximeter** warnings and cautions



WARNING Use only Nellcor **OxiMax** sensors and accessories. Connecting any other cable or sensor influences the accuracy of the sensor data, which may lead to adverse results.



WARNING Pulse CO-Oximeter readings and pulse signals can be affected by certain ambient conditions, sensor application errors, and certain patient conditions. Examples: excessive patient movement, medical procedures, or external agents such as dysfunctional hemoglobin, arterial dyes, low perfusion, dark pigment, and externally applied coloring agents such as nail polish, dye, or pigmented cream.



WARNING Failure to cover the sensor site with opaque material when operating under high ambient light conditions may result in inaccurate measurements. **Pulse CO-Oximeter** readings and pulse signals can be affected by certain environmental conditions, sensor application errors, and certain patient conditions.



WARNING Carefully read the sensor Instructions for Use, including all warnings, cautions, and instructions.



WARNING Do not use a damaged sensor or interface cable. Do not use a sensor with exposed optical components.



WARNING Incorrect application or inappropriate duration of use of a sensor can cause tissue damage. Inspect the sensor site as directed in the sensor's Instructions for Use.



WARNING Do not immerse or wet the sensor.



CAUTION Verify the movement of the blip bar, plethysmographic waveform, or pulse identification indication (eg. audible beepnow) before accepting **Pulse CO-Oximeter** data as a current measurement.



NOTE Consult sensor Instructions for Use for proper sensor application.



NOTE Use only differentially wired extension cables.

Controls, indicators, and connectors



NOTE Your model might not contain all of these features.

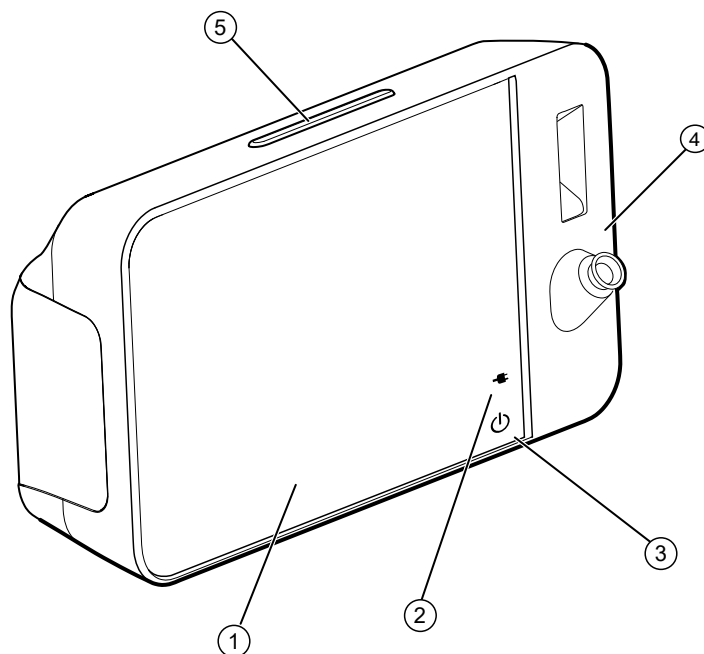

Front-Left view

No.	Feature	Description
1	LCD screen with branding	12.1" color touchscreen provides a graphical user interface
2	Battery charge and power-up status indicator	The LED indicates the charging and power-up status when connected to AC power: <ul style="list-style-type: none"> • Green: The battery is charged • Amber: The battery is charging • Flashing: The monitor is powering up
3	Power button	Button on lower-right of the monitor: <ul style="list-style-type: none"> • Powers on the monitor • Powers down the monitor • Places the monitor into Sleep mode with a short press, except when an alarm condition is active • Wakes up the monitor from Sleep mode
4	Thermometry	SureTemp Includes probe well and probe covers compartment
5	Light bar	Provides a visual alarm with red and amber LEDs.

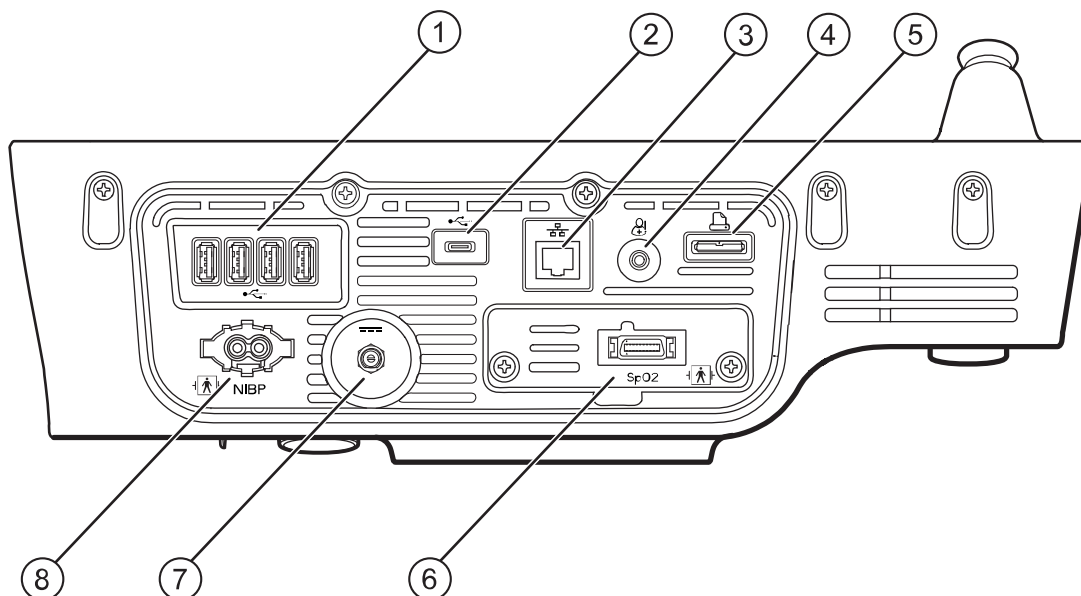

Bottom view

No.	Feature	Description
1	USB ports (4)	Connect accessories to the monitor. Supported accessories include barcode scanners and RFID readers.
2	USB-C port	Provides a connection to an external computer
3	Ethernet RJ-45	Provides a hardwired connection to a network.
4	Nurse call	Provides a connection to a hospital nurse call system
5	Printer (future feature)	Connects to a printer (future release)
6	SpO2	Connects chosen SpO2 system to monitor (Type BF applied part, Masimo SET SpO2, or Nellcor SpO2)
7	Power connection	Connects to power supply
8	NIBP connection	Connects NIBP hose to monitor

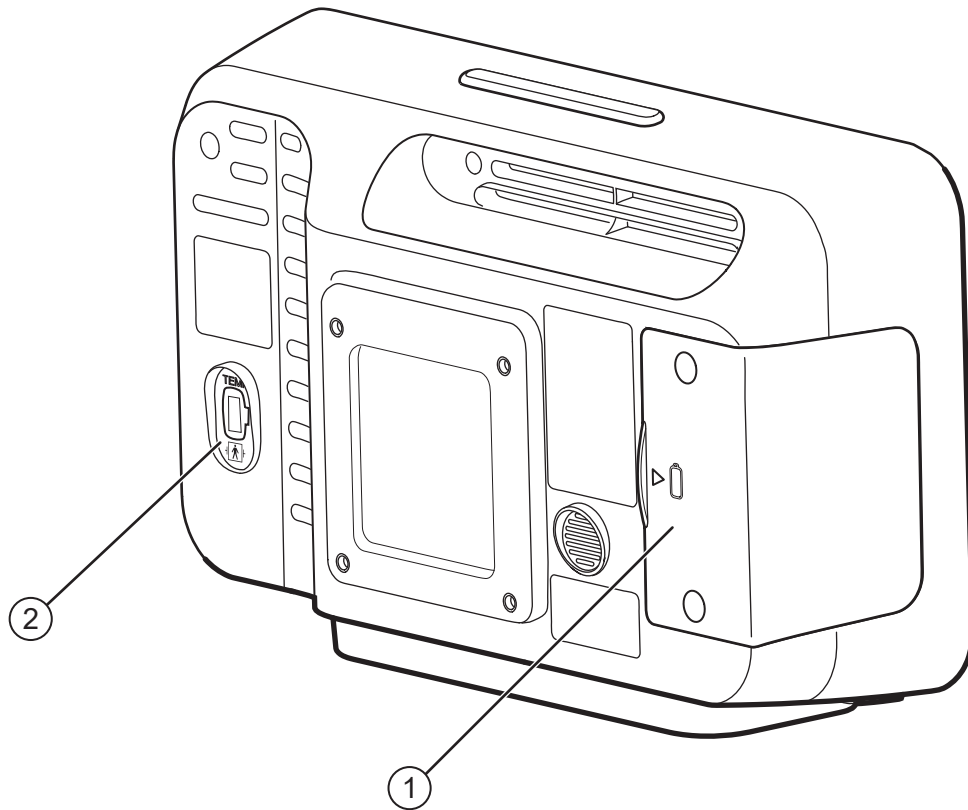

Back view

No.	Feature	Description
1	Battery door	The battery door covers the battery compartment that houses the battery (The captive screws secure the battery door to the monitor.)
2	SureTemp thermometry connection port	Configuration shown features SureTemp module probe connection port

Setup

Supplies and accessories

For a list of all approved supplies and accessories, see "Approved Accessories" in the Appendix.

CAUTION Patient injury risk. Clean all accessories, including cables and hoses, before storing the accessories on the device or cart. This helps reduce the risk of cross contamination and nosocomial infection. Refer to 'Prepare to clean and disinfect the equipment' in "Maintenance and service" for instructions.

Insert the battery

This procedure applies to first-time setup of the monitor. The battery is inserted in the battery compartment when you receive a new monitor. However, it may not be connected or charged.

WARNING Personal injury risk. Improper handling of the battery can lead to heat generation, smoke, explosion or fire. Do not short-circuit, crush, incinerate, disassemble, or use an unapproved battery pack. Never dispose of batteries in refuse containers. Always recycle batteries according to national or local regulations.

WARNING Use only approved accessories, and use them according to the manufacturer's instructions for use. Using unapproved accessories with the monitor can affect patient and operator safety and can compromise product performance and accuracy, and void the product warranty.

1. Locate the battery door, indicated by  on the back of the monitor.

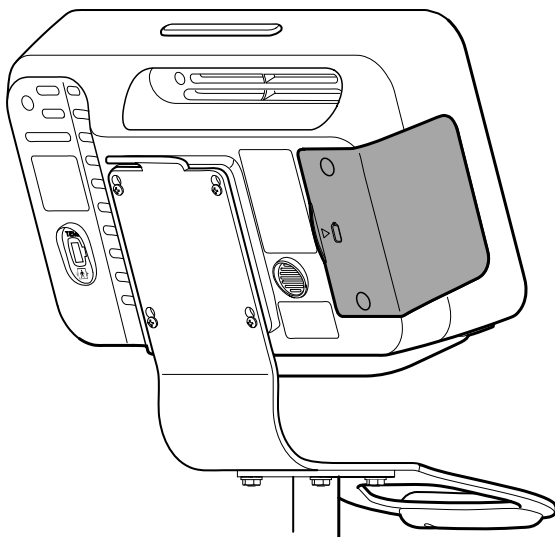

2. Using a double-slotted screwdriver, loosen the captive screws of the battery door, and then remove the door.

3. Slide the battery into the battery compartment.



NOTE Do not remove the tab label from the battery. This tab helps you remove the battery from the compartment when you need to replace it.

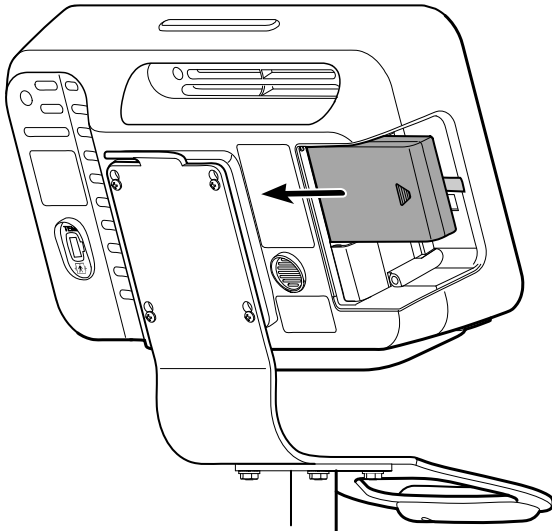

4. Replace the battery door, and then tighten the captive screws of the battery door.



NOTE Do not over-tighten the screws.

Mount the monitor onto the mobile stand

The **Connex 360** monitor can be mounted on a mobile stand or mounted to the wall. For the wall mount, follow the assembly instructions or instructions for use included with your wall mount. When mounted, a separate power supply is required that does not come with the mobile stand or wall mount packaging. Check the monitor packaging for the power supply.

1. Follow the assembly instructions included with your mobile stand to assemble the base caster and wheels, the pole pieces, the bins, and the mobile stand support bracket before attempting to mount the monitor.

2. Thread each of the 4 supplied screws (8 mm) into the monitor's mounting plate leaving a gap of 6 mm. (The gap needs to be large enough to accommodate the thickness of the support bracket).

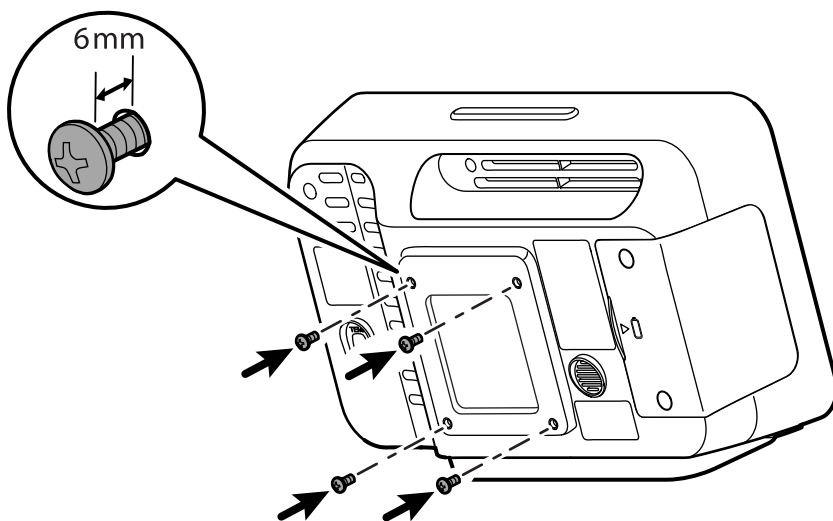

3. Attach the monitor onto the mobile stand support bracket by aligning the 4 mounting screws with the 4 openings of the bracket and then slide the monitor down into the 4 grooves of the bracket as illustrated.

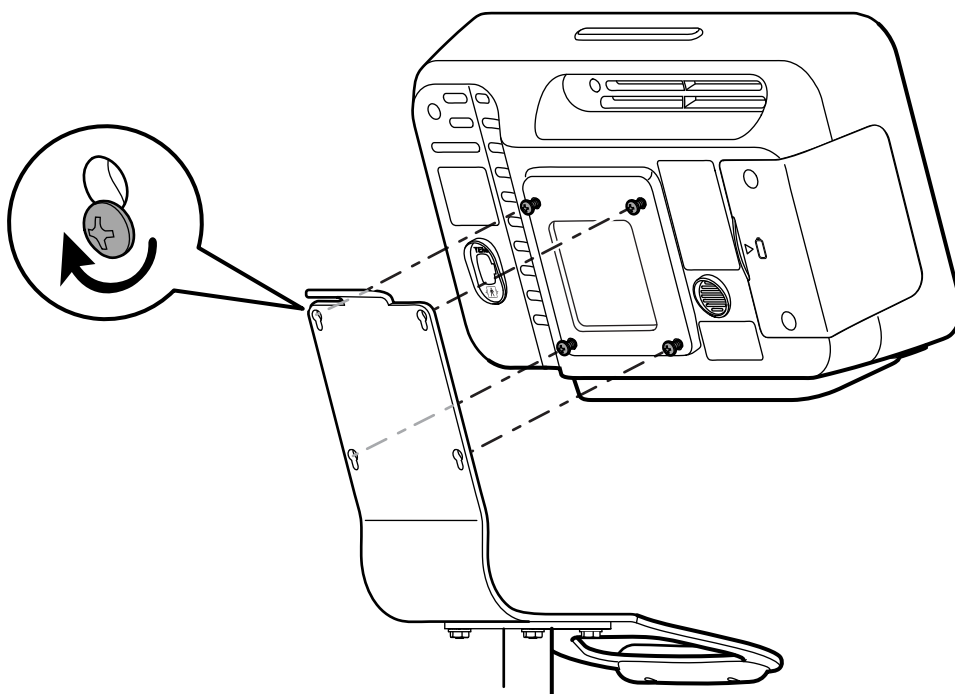

4. Tighten the 4 mounting screws until each of the screw heads are flush with the bracket and the monitor is secure.

Connect AC power to a power source

You can use the monitor with either power from the AC mains outlet, or battery power after charging the battery.

Setup

To power the monitor from the AC mains outlet, insert the power plug into an outlet to power the monitor and to charge the battery.

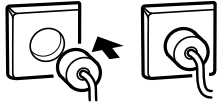

NOTE New batteries are only partially charged. You must plug the monitor into AC power to fully charge the battery. Do not plug in the power cord until completing all preliminary steps.



NOTE The device switches to battery power when the power connection is removed.

Connect AC power to the wall mounted monitor

To connect power to the monitor mounted to the wall, refer to the *GCX Assembly instructions*.

Connect AC power to the monitor mounted onto the mobile stand

Follow the assembly instructions included with your mobile stand to assemble the base caster and wheels, the pole pieces, the bins, and the mobile stand retaining bracket with power supply before attempting to connect the AC power.

1. Feed the output power connector up through the channel of the bins compartment as illustrated.

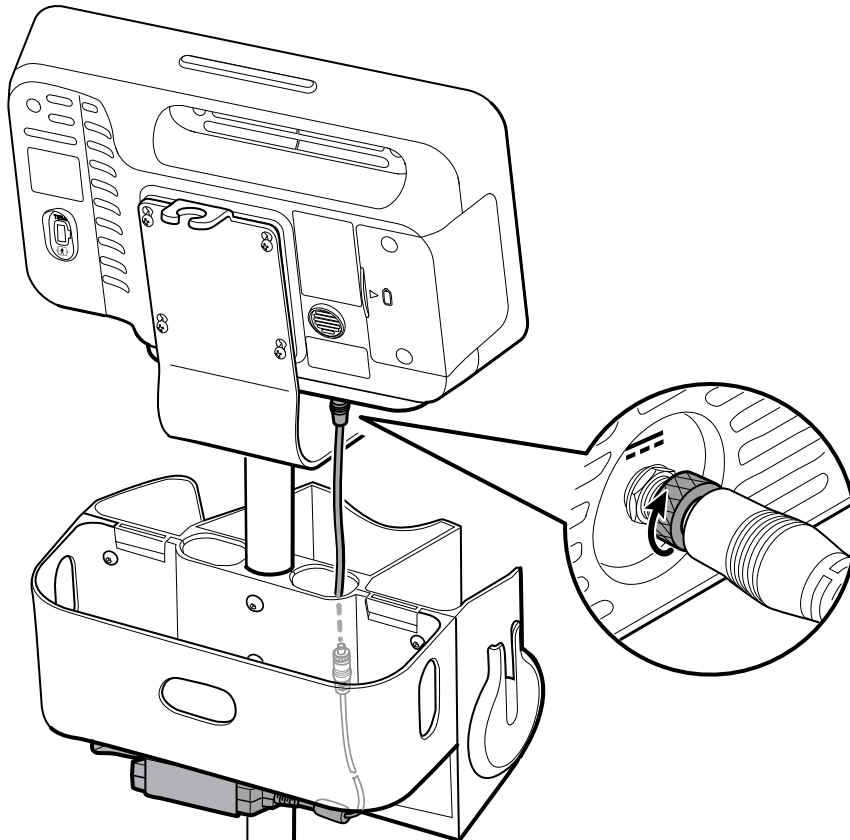

2. Connect the output power connector to the bottom of the monitor at the DC power connection source indicated by the icon .
3. Hand-tighten the retaining ring of the output power connector by turning the retaining ring clockwise to secure the power connector to the monitor.
4. Plug the AC power cable into the inlet of the power supply that was previously mounted onto the bottom of the bins compartment, wrap any excess power supply cord around the cord wrap of the mobile stand, and then insert the power plug into an outlet to power the monitor and to charge the battery.

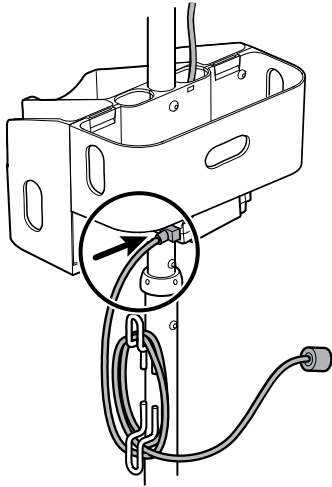

Disconnect AC power



CAUTION Never move the monitor or mobile stand by pulling on any of the cords. This may cause the monitor to tip over or damage the cord. Never pull on the power cord when disconnecting the cord from the mains outlet. When disconnecting the power cord, always grasp by the attachment plug. Keep the cord away from liquids, heat, and sharp edges. Replace the power cord if the strain relief, cord insulation, or metal prongs are damaged or begin to separate from the attachment plug.

1. Grasp the power cord by the attachment plug.
2. Pull the power cord attachment plug out from the mains outlet.
3. When not in use, set the power cord attachment plug into the catch on the top of the mobile stand support bracket to keep the power cord clear of the wheels and to minimize trip hazards.

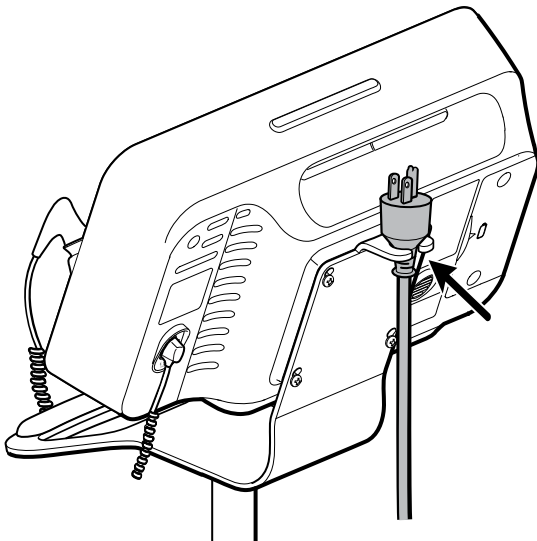

Attach the probe well and temperature probe



NOTE The **SureTemp** thermometer conforms to all of the requirements established in ASTM Standard E1104. Full responsibility for the conformance of this product to the specification is assumed by Baxter.

The operator is responsible for checking the compatibility of the monitor, probe, and probe cover before use.



NOTE Use the blue probe well and the associated oral and axillary temperature probe kit for oral and axillary site measurements. Use the red rectal probe well and the rectal temperature probe kit for rectal site measurements. Once powered on, the monitor auto-detects the probe type after the probe is connected.

For a list of all approved temperature probe kits and probe wells, see "Approved Accessories" in the Appendix.

1. Align the slots on the monitor and probe well, and slide the probe well into the monitor. The probe well snaps into place when it is fully seated.

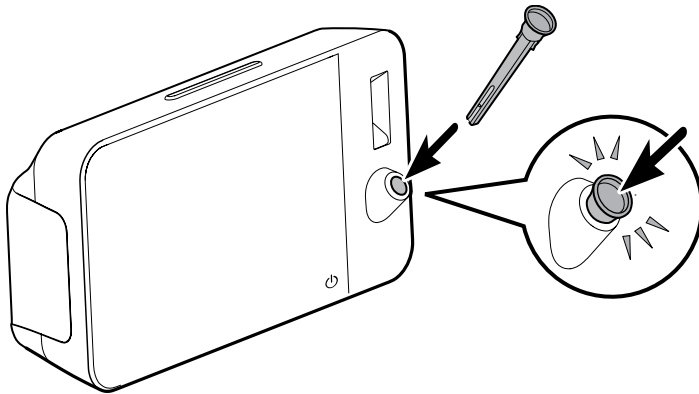

2. Attach the **SureTemp** probe connector to the back of the monitor at the **SureTemp** connection port.

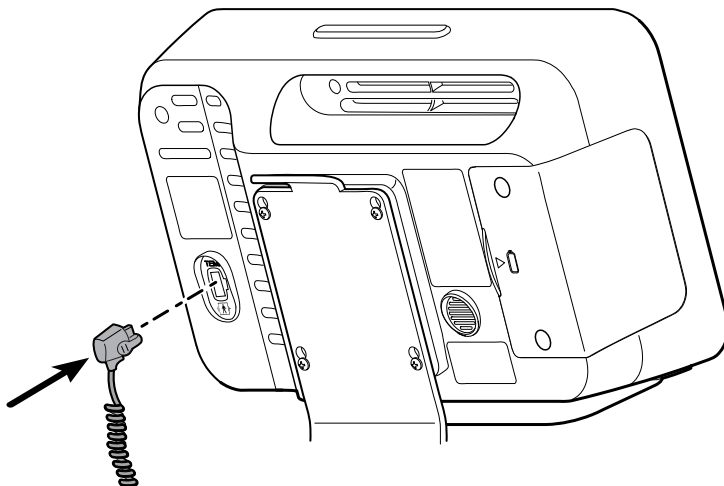

3. Insert the **SureTemp** probe into the probe well.

4. Insert a box of Baxter probe covers into the compartment above the probe well.

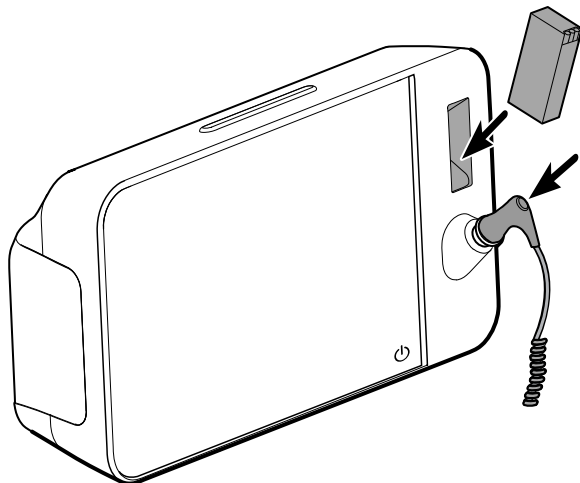

Additional cartons of probe covers can be stored in the lower compartments of the mobile stand bins if a mobile stand is used.

Remove the temperature probe and probe well

Follow these steps to disconnect the probe cable and remove the probe well.

1. Press the spring tab on the **SureTemp** probe connector and pull it out of the connection port. The probe connector port is located on the back of the monitor.
2. Remove the **SureTemp** probe from the probe well.
3. Grasp the probe well and pull it up to remove it from the monitor.

Connect the NIBP hose

1. Place your thumb and forefinger on the hose connector spring tabs and squeeze firmly.
2. Align the hose connector with the hose connector port on the bottom of the monitor.
3. Insert the hose connector, pressing firmly until both of the spring tabs click into place.

Disconnect the NIBP hose

1. Place your thumb and forefinger on the hose connector spring tabs.



NOTE Always grasp the hose by the connector spring tabs. Do not pull on the hose itself.

2. Squeeze and pull the spring tabs until the connector releases.

Connect the SpO2 sensor



WARNING Patient injury risk. Do not use a damaged sensor or pulse oximetry cable or a sensor with exposed electrical or optical components.



NOTE The operator is responsible for checking the compatibility of the monitor, sensor, and cable before use.

1. Align the 2 notches of each of the cable halves and insert the SpO2 sensor end of the cable into the receptacle end of the cable half that attaches to the monitor's connection port. Close the cover to secure the connection of the 2 halves of the SpO2 cable.

For full assembly instructions, follow the instructions that accompany the accessory.

2. On the bottom of the monitor, align the SpO2 cable connector with the cable connector port.
3. Insert the cable connector, pressing firmly until the connector is seated.

Disconnect the SpO2 cable

1. Place your thumb and forefinger on the SpO2 cable connector. Do not grasp the cable.
2. Gently squeeze the release clips.
3. Pull the SpO2 cable connector out of the connector port.

Attach an accessory



CAUTION Accessories attached to this monitor must run on battery power. Do not use any accessory's external power supply when it is attached to the monitor.



CAUTION Connect cables in a manner that minimizes entangling.

To attach an accessory to the monitor, follow the instructions that accompany the accessory.

Detach an accessory

To detach an accessory from the monitor, follow the instructions that accompanied the accessory.

Connect a Barcode scanner or RFID reader to a USB port



NOTE For set up details, follow the instructions that accompany the accessory. To see illustrated instructions of a barcode scanner or RFID reader holster mounted to the bins compartment of the mobile stand, refer to the *Startup guide* instructions and the manufacturer's instructions.

For a list of all approved RFID readers and barcode scanners, see "Approved Accessories" in the Appendix.

1. Once the RFID reader or barcode scanner holster is attached to the bins compartment of the mobile stand, set the RFID reader or barcode scanner into the holster.

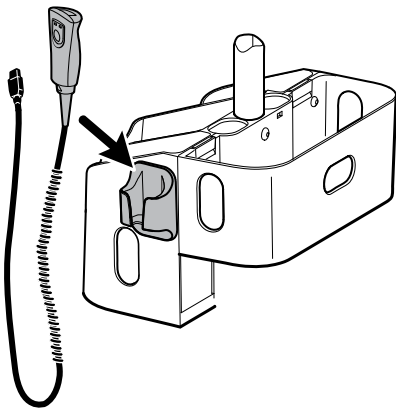

2. Feed the RFID reader or barcode scanner USB cable up through the channel of the bins compartment as illustrated.

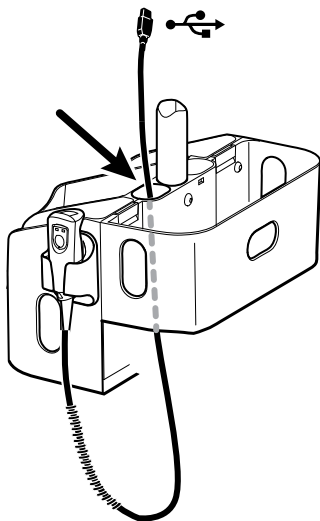

3. Plug the RFID reader or barcode scanner USB cable into 1 of the 4 USB communication ports located at the bottom-left of the front of the monitor. The USB communication ports are indicated by the USB icon.

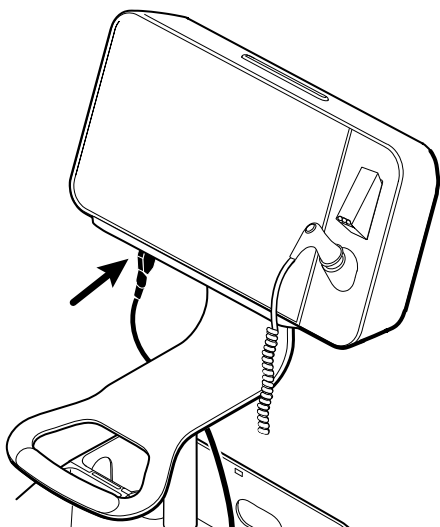



Setup

Startup

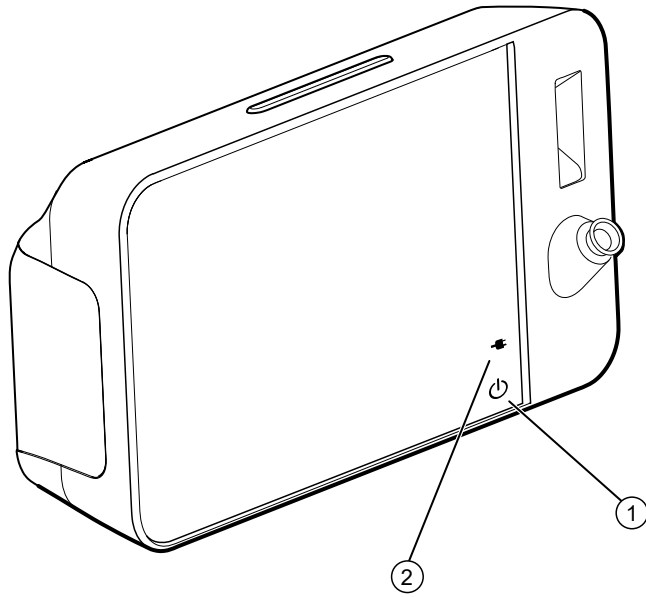
Power





No.	Feature	Description
1	Power button 	Button on lower-right of the monitor: <ul style="list-style-type: none">• Powers on the monitor• Powers down the monitor• Places the monitor into Sleep mode with a short press, except when an alarm condition is active• Wakes up the monitor from Sleep mode
2	Battery charge and power-up status indicator	The LED indicates the charging and power-up status when connected to AC power: <ul style="list-style-type: none">• Green: The battery is charged• Amber: The battery is charging• Flashing: The monitor is powering up

 **WARNING** Do not use a long press of the Power button  to power down the monitor when it is functioning normally. You will lose patient data and configuration settings. Touch the **Settings > Device** tabs to power down the monitor.

Power up the monitor

- Press  to power up the monitor.

When the device is powering up, the LED flashes until the monitor displays the startup screen and a power-up tone sounds.

When the device is not plugged into a power source, after a brief touch of the power button , the device displays a solid green power icon  if the device is charged to greater than or equal to 90%, a solid amber icon  if the device is charged to greater than or equal to 40% and less than 90%, and an amber icon that flashes 3 times if the device is charged less than 40%.

The monitor runs a brief diagnostic self-test each time it powers up. If an alarm situation occurs, the alert appears in the device's Status area at the top of the screen. Shown is an example of a Cyan-colored, very low alarm that may appear at power up if the battery needs to be recharged.



 **WARNING** To ensure patient safety, listen for two audible indicators (a beeper and a speaker tone) and watch for visual alerts at power-up at least once daily. Correct any system errors before using the monitor. In addition to the audible indicators, the screen Status area displays color coding, icons, and messages that help you to distinguish clinical priority and actions, if needed.





 **WARNING** Steady amber indicates a low-level alarm. Flashing amber indicates a medium-level alarm. Flashing red indicates a high-level alarm.

 **WARNING** Always observe the monitor during power-up. If any display fails to illuminate properly, or if a system fault code or message displays, inform qualified service personnel immediately, or contact your nearest Baxter Technical Support. Do not use the monitor until the problem is corrected.

 **CAUTION** During intervals monitoring, keep the monitor connected to AC power at all times.

 **CAUTION** Use only a Class I (grounded) AC power cord to charge the battery for this monitor.

The following alerts, displaying the number of active alarm messages, may appear in the device's Status area at the top of the screen depending on the condition and your monitor's configuration and functionality.

Type of alert	Color	Alarm icon example
High Alarm	Flashing red	
Medium Alarm	Flashing amber	
Low Alarm	Steady amber	
Very Low Alarm	Cyan	
Information message	Blue	

- On initial power-up, the monitor prompts you to set the language, date, and time. See "Change the language" and "Set the date and time" for directions.
- If your facility has chosen a login format, then the first image you see is the login screen.
- If your facility has not chosen a login format, then the first image you see is the Home tab.

Set the date and time

Depending on your facility's configuration, the date and time may already be set. If the time is set in the network configuration, the network time overrides any manual time that is set.

1. Touch the **Settings** tab.
2. Touch the horizontal **Device** tab.
3. Touch the ▲ or ▼ keys to set the date and time.





NOTE The date and time stamps on saved patient measurements will adjust when you change the date and time settings.

Change the language

Refer to "Advanced Settings" in the Service manual for instructions on how to change the language.



Power down the monitor

If you power down the monitor using , patient measurements are retained in the monitor memory for a maximum of 24 hours. These saved measurements are available for recall or electronic transmission to the network. This method also ensures that any configuration settings you have changed and saved will be maintained at the next startup.

1. Press .
 - If there is a software update available, then a system message asks if you want to upgrade the software.
2. If you want to upgrade the software, touch **OK**.
3. If there is no system message, a dialog box appears with options.
 - Sign out (if you signed in with a Clinician ID)
 - Power down
 - Sleep
 - Cancel
4. Touch one of the options.

The monitor will either sign you out as a clinician so that another clinician can sign in, power down, go into Sleep mode, or return to the prior screen, depending on the option you choose. The battery continues to charge when in Sleep mode.

Restart the monitor

1. If the monitor stops functioning, press and hold , located on the lower-right of the monitor, to reset the monitor.
2. If there is a prompt with options to power down, Sleep, or Cancel, continue to press .

The monitor performs a power reset.



WARNING Do not use a long press of  to power down the monitor when it is functioning normally. You will lose patient data and configuration settings. See "Power down the monitor" to power down the monitor.

Sleep mode

After a configurable amount of time, the monitor enters sleep mode. Different types of inactivity have different time delays:

- When a configurable amount of time has passed since the last screen press
- When the sensor modules are not being used to capture vitals
- If the monitor does not have an active alarm

The monitor does not enter sleep mode when it is in Intervals monitoring.

Three situations cause the monitor to leave sleep mode:

- The power button is pressed.
- The screen is tapped.
- An alarm occurs.

Enter Sleep mode

1. Press .
2. If there is no system message, a dialog box appears with options.
 - Sign out (if you signed in with a Clinician ID)
 - Power down
 - Sleep
 - Cancel
3. Touch **Sleep**.
The monitor enters Sleep mode.

Exit Sleep mode

1. Press .
(If your facility has chosen a login format, the Login dialog box appears.)
2. If you are the current user and are in a facility-specific login format, use the scanner or keypad to enter your ID and password.
If you are logging back into the monitor, the monitor returns to the screen that previously was visible, keeps the patient's context, and maintains the vital signs that could have been previously captured.
3. If you are a new user, use the barcode scanner or keypad to enter your ID and password.

Overview

Clinician Login

Sign in manually or via the login screen, if your facility has chosen a login format.

Log in manually

Clinicians will log in manually when an alternative login format is not active.

1. From the home screen, touch the clinician login button  in the upper left corner.
2. Use the onscreen keyboard to enter the clinician ID and password. Alternatively, scan a barcode, if enabled.

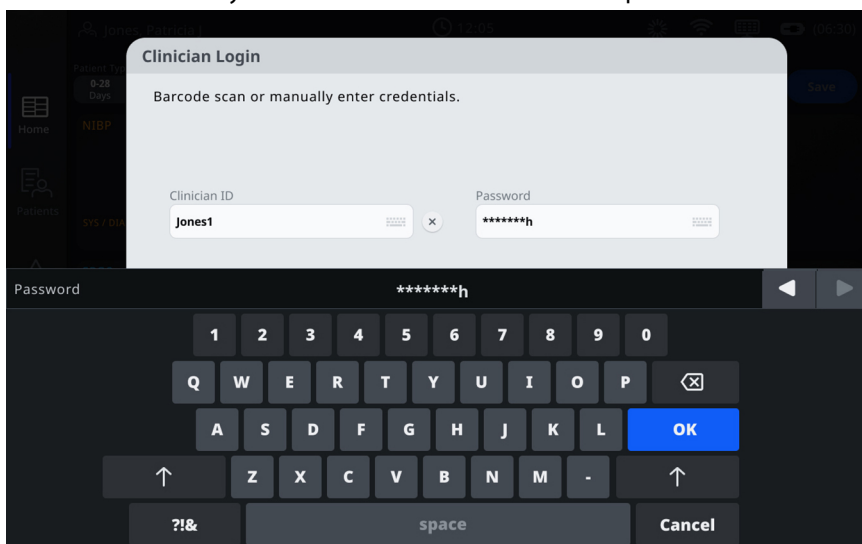

3. Touch **Log in**.

Log in with RFID reader

The monitor enables the scanning of clinician RFID badges to enter ID information. The RFID reader supports linear and two-dimensional barcodes and RFID badges.

If you have not done so previously, use the instructions provided with the RFID reader to attach to the monitor.



NOTE Refer to the manufacturer's instructions to ensure that the RFID reader is set to "USB Com Emulation" mode. Confirm the type of EMR version being used by your facility.

1. Place a clinician badge (RFID or two-dimensional barcode) so the light from the RFID reader appears on the clinician badge. The system will verify the number and log in the clinician.

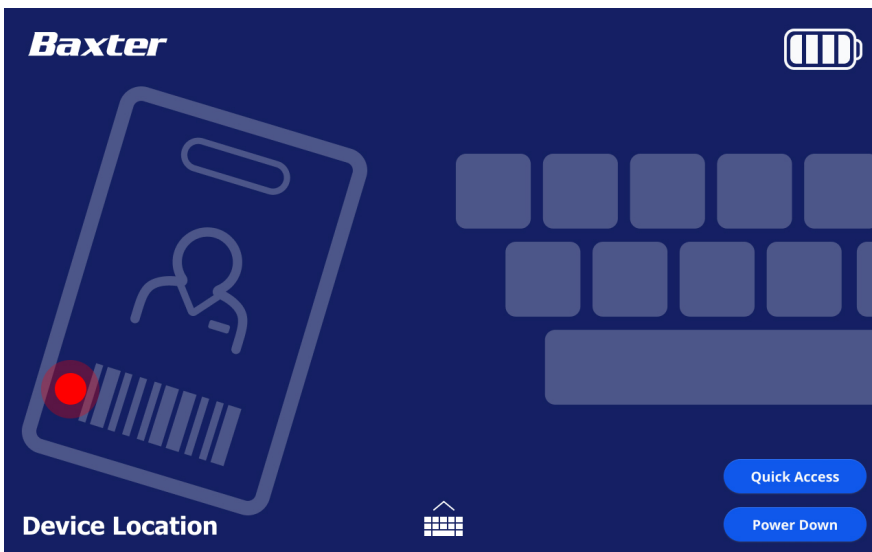

2. Optional: Touch  to enter credentials manually.
3. Optional: Touch **Quick Access** to skip login and to proceed to the Home screen without a clinician ID.
4. Optional: Touch **Power Down** to power down the monitor. Touch **Confirm** or **Cancel** at the Confirm Shutdown dialog box.

Once the RFID reader completes a successful RFID badge reading and any required queries for a matching ID on the device or an external host system are met, the ID appears in the targeted area (data field, or Device Status area). See the additional note below.

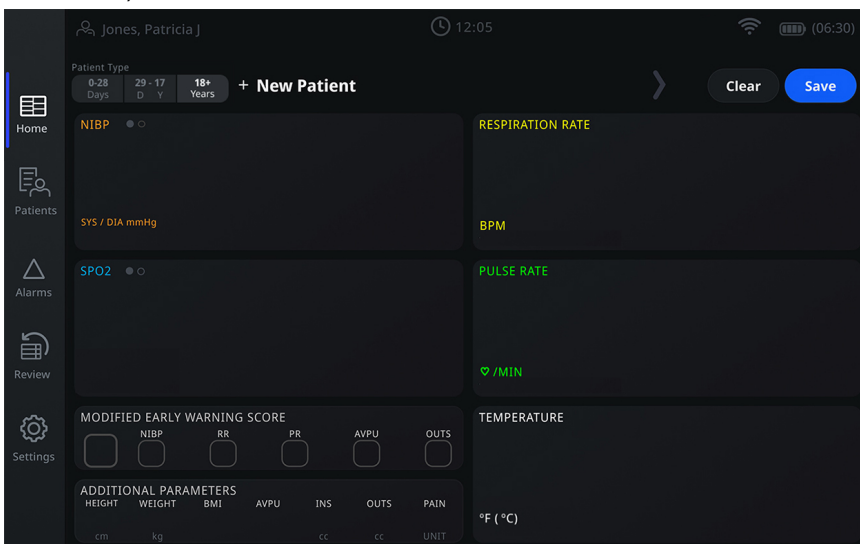

NOTE If the RFID reader has difficulty reading the RFID badge, slowly adjust the distance and the angle between the RFID reader and the RFID badge. If it continues to have difficulty, verify that the RFID badge is as flat as possible.

Log in using the Clinician login screen



1. Touch  to enter the credentials screen.
2. Using the keyboard, enter your ID and password in the respective fields, and then touch **Login**.

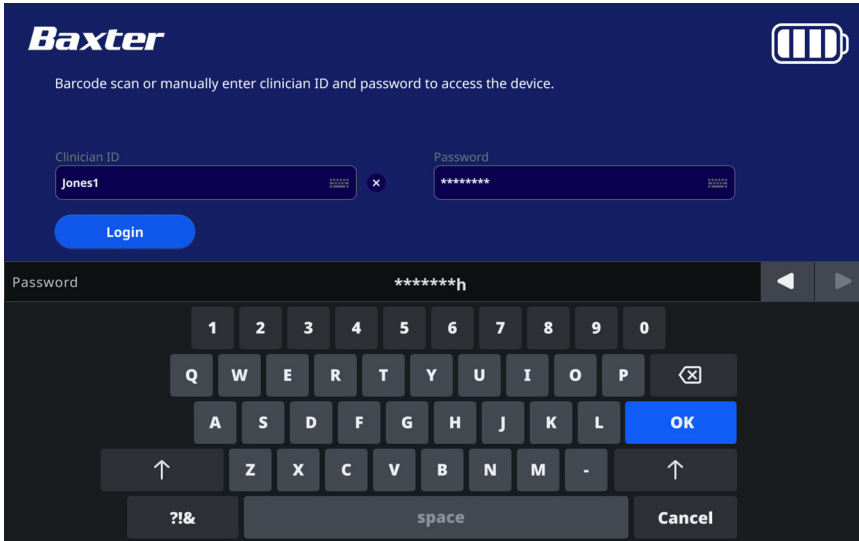



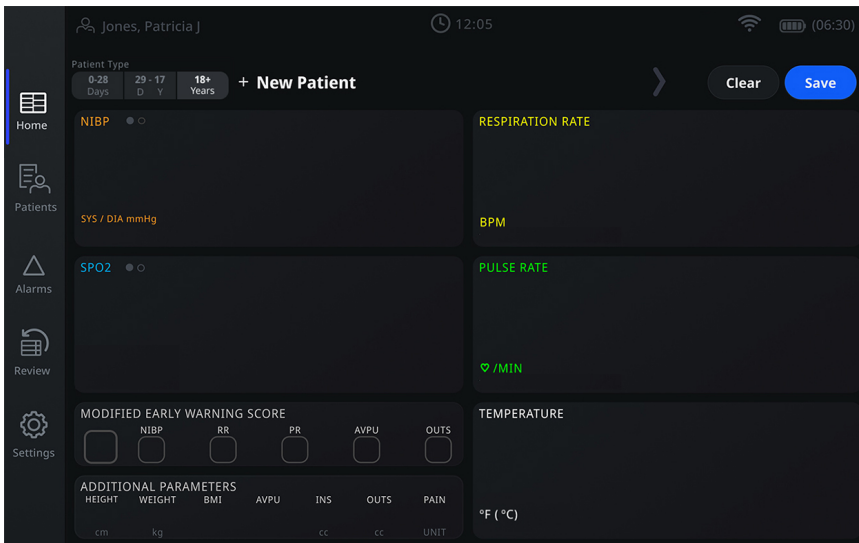





When signed in the Clinician ID appears in the Status area, depending on your configuration. The vertical icons may vary, depending on your configuration.



Common screen functionality

Many parameter areas on the screen allow you to enter data. Touch an icon to perform the function noted.

Icon	Description
	Numeric keypad for entering numeric information.
	Alphanumeric keyboard for entering both alpha and numeric information.

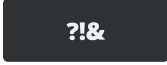
Icon	Description
	Shift key enters the next letter touched as uppercase.
	Data field in which data is entered.
	Backspace key deletes data one character at a time, starting from the last character entered. Each touch removes one character.
	Navigation keys capture the data entered and advances to the next field (right button) or returns to the previous field (left button). The active field is outlined in blue.
	OK key captures entered data and closes keypad or keyboard being used to enter data.
	Cancel key closes the keypad or keyboard without capturing entered data.
	Alpha key in the lower-left corner returns the keyboard to the basic alpha layout.
	Symbol key in the lower-left corner changes the keyboard from the basic alpha layout to the symbols and special characters layout.

Primary screens

The monitor has primary screens and pop-up screens. The example screen shown below is for Spot monitoring of a patient.

The Respiration Rate frame is an optional, licensed feature showing Masimo **RRp** respiration rate measurement. Once licensed, **RRp** can be configured using the Welch Allyn Product Configuration Tool.

The primary screens have three sections:



Item	Description
1 Status	Status area appears at the top of the screen and includes information regarding system-wide features.
2 Content	The Content area displays information determined by the primary — or global — navigation tab chosen at the left side of the screen. The content area also might have tabs that relate to the primary navigation tab chosen. It also can display summary information on current vital signs.
3 Primary navigation	The primary navigation tabs appear at the left side of the screen.

Battery status

The battery status indicator displays the state of the battery.

The battery status is represented by icons in the upper-right corner of the monitor display. The status represents several possible situations:

- The monitor is connected to a power source and the battery is charging or is fully charged.



The amount of battery charge is shown in the format of percentage charged.

- The monitor is not connected to a power source and is running on battery power. The estimated display time



remaining is shown in the HH:MM format and battery charge with 0–4 bars.



- The monitor is connected to a power source but the battery does not maintain a charge (or has been removed).



Bars	Description
4	Running on battery, battery charge is very high, 75 - 100%, display time remaining (HH:MM)
3	Running on battery, battery charge is high, 50 - 74%, display time remaining (HH:MM)
2	Running on battery, battery charge is medium, 25 - 49%, display time remaining (HH:MM)

Bars	Description
1 	Running on battery, battery charge is low, 11 - 24%, display time remaining (HH:MM)
0 	Running on battery, display charge is very low, 0 - 10%, display time remaining (HH:MM)

When the battery is not being recharged and power becomes low, an amber, very low-priority alarm appears in the Status area.



NOTE Monitor the remaining battery charge in the battery status indicator and plug the monitor into a power outlet as soon as you are able.

If the low-priority alarm is dismissed or if you take no action to charge the battery, a red, high-priority alarm appears and sounds when battery power is critically low. Plug the monitor into a power outlet immediately to prevent the monitor from powering down.

Alarm and information messages

The Device Status area provides alarm and information messages that are either temporary or exist as long as the condition to which the message applies remains. Alarm or information messages may also include controls or behavior that you can use to manage alarm and information messages.

When the monitor detects an alarm condition, the vitals frame relating to the alarm flashes and an alarm message appears. When multiple alarms occur, the highest priority message appears first. You can cycle through each alarm message by touching the multiple alarm toggle.

Information messages instruct you to interact with the monitor in a specific way or provide information that does not require action. You can dismiss an information message by selecting the control associated with the message or waiting for the message to time out.

Screen lock mode

The screen lock blocks the display of patient information and prevents any input, which may be useful when cleaning the display, or if you need to conceal information.

The screen locks when any of the following occur:

- You touch **Display lock**.
- There is no interaction with the monitor (if established during facility-based configuration)

Lock the screen

Follow these steps to touch the screen without activating the controls.

1. Touch the **Settings** tab.
2. Touch the **Device** horizontal tab.
3. Touch **Display lock**.

Unlock the screen

Simply touch the lock icon to unlock the screen for manual unlock of the monitor when not using a Clinician ID login configured for your site and when not using Single-Sign-On.

Follow the steps below for Single Sign On configurations and for Required clinician authentication. Sample screen shown with Intervals running and Clinician ID login configured:



1. Using a RFID Reader, scan your ID badge.

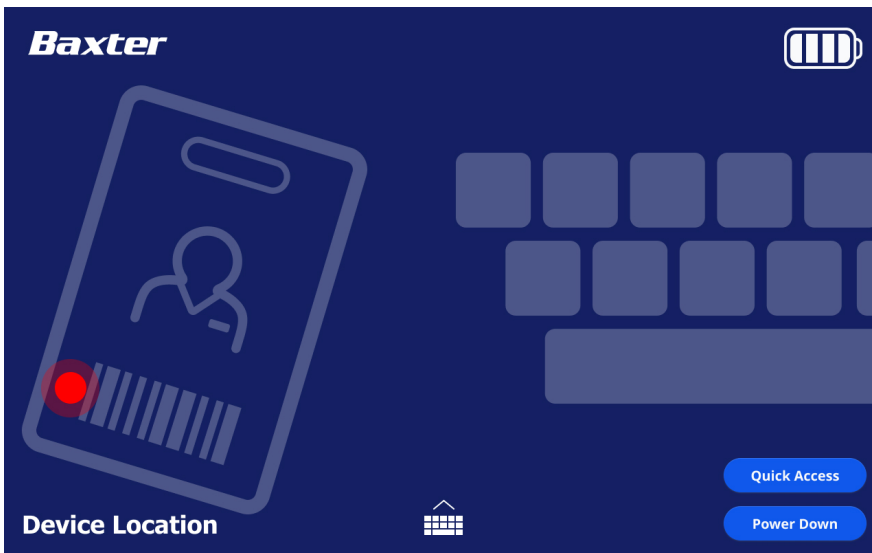

- Optional: Or use the keypad to enter your ID and password. Follow the onscreen prompts to unlock the screen.

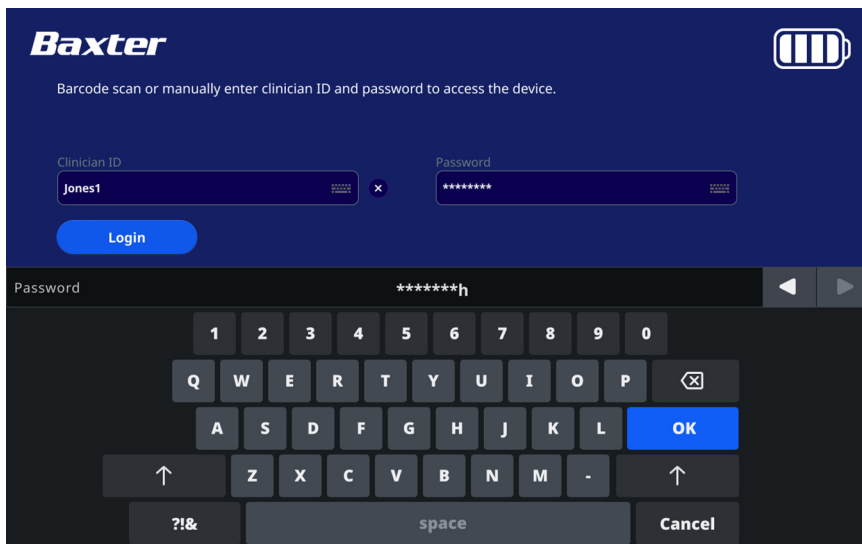

You log back into the monitor by either scanning your ID badge or manually entering your ID and password. When you attempt to log on to a monitor that a previous user has already logged into, a dialog box appears: "Would you like to log the current user, XXX, out?"

If you select No, then the previous user remains logged on and the lock screen remains on the screen. If you select OK, then the device logs out the previous user, logs you in, and takes you to the Home tab.

Pop-up dialogs or screens

Pop-up dialogs in the Device Status area provide alarm and information messages that are either temporary or exist as long as the condition to which the message applies remains. Alarm or information messages may also include controls or behavior that you can use to manage alarm and information messages.

When the monitor detects an alarm condition, the vitals frame relating to the alarm flashes and an alarm message appears. When multiple alarms occur, the highest priority message appears first. You can cycle through each alarm message by touching the multiple alarm toggle.

Information messages instruct you to interact with the monitor in a specific way or provide information that does not require action. You can dismiss an information message by selecting the control associated with the message or waiting for the message to time out.

When a pop-up screen appears, you cannot access any buttons or controls on the screen behind the pop-up. The specified action on the pop-up screen must be accomplished or, if allowed, actively dismissed or canceled, before other screens become active.

There are instances when multiple, layered pop-up screens occur. In these instances, only the top pop-up screen is accessible. The specified action on the top pop-up screen must be accomplished or, if allowed, actively dismissed or canceled, before the pop-up screen behind becomes active.

Navigation

There are two types of navigation in the monitor:

- Primary navigation tabs
- Command buttons

Primary navigation tabs

The primary navigation tabs located on the left side of the screen enable you to switch between tabs and change the controls in the content area on the monitor. The tab you choose determines what information appears on the screen. The five navigation tabs are:

- Home
- Patients
- Alarms
- Review
- Settings



NOTE The patients tab is displayed when the device is configured to query a patient list from the network, such as electronic medical records (EMR) system, health information system (HIS), **HL7** records, etc..

Command buttons

Command buttons and icons, such as the Intervals icon or the Clinicians icon, enable you to navigate and perform actions.

Home tab

The Home tab displays patient information.

In the action area, touch Save to record the vitals to the patient record and clear the screen. Touch Clear to select a new patient. A confirmation pop-up requires response, then you can choose a new patient from the EMR.

Patient data is displayed on the Home tab. To view more detailed information, touch the patient area to access Patient Context.

Patient demographics data is managed through the Patients tab. The Patients tab is displayed when the device is configured to query a patient list from the network, such as electronic medical record (EMR) system, health information system (HIS), **HL7** records, etc..

Home screen without patients tab available:

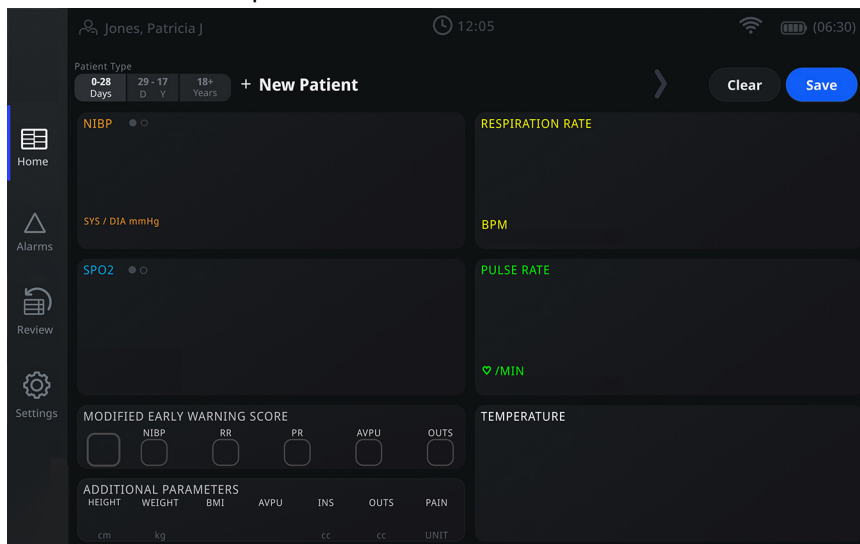

The Home screen showing the Patients tab, a Spot check screen, and a facility-enabled Early Warning Score section:

Overview

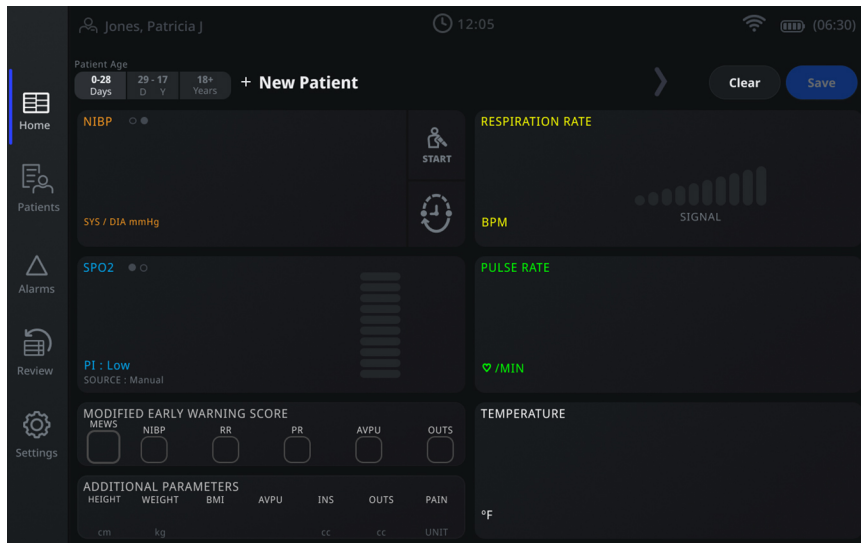

The following example shows an Intervals screen with modifiers enabled:



For both Spot check and Intervals monitoring, the common screen areas include:

- Status area, with alarm status and battery status
- Patient area, with patient type, patient name, DOB, and MRN
- Action area, with Clear and Save
- NIBP
- SpO2
- Custom scoring (Modified Early Warning Score/additional parameters – if configured for your facility)
- Respiration rate (if configured for your facility)
- Pulse rate
- Temperature

Alarms tab

The Alarms tab contains the following horizontal tabs:

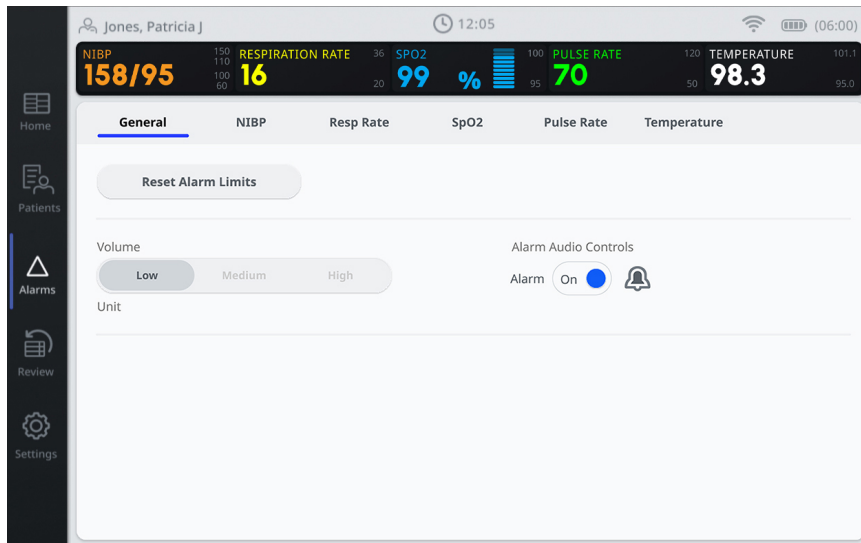

- General
- NIBP
- Resp Rate (if configured for your facility)
- SpO2
- Pulse Rate
- Temperature

The General tab contains parameter controls to reset alarm limits, adjust volume, and turn alarm audio controls on or off. The remaining tabs contain controls to set alarm limits.

Review tab

The Review tab displays previously captured patient data. The Review tab displays both core and custom parameters, as well as:

- Controls to Delete or Send records
- Patient Name
- Date & Time
- Custom parameters
- Core parameter values (PR, SpO2, RR, NIBP, Temperature)

Data can be viewed for multiple patients or for a single patient. To access the single patient view touch the > icon next to the patient.



NOTE Measurements that triggered a physiological alarm are highlighted with color.



NOTE The  icon indicates the records have been sent to the network.

Multiple patient view:

Overview

Patient	Date/Time	MEWS	NIBP	Temp	PR	RR	SpO2
Bryant Beatty 7874729	10/18 12:30	1	122 / 80	100.5	76	17	99
Shari Tremblay 8872686	10/18 11:00	0	140 / 82	98.4	85	19	99
Owen Kovacek 2357265	10/18 10:20	3	146 / 82	103.5	135	19	96
May Bartell 9896835	10/18 9:10	0	130 / 86	97.9	80	25	99
Elvira Goldner 5432452	10/18 9:00	0	135 / 89	98.5	88	12	100
Eugene Davis 1454367	10/18 8:01	0	134 / 90	98.9	76	17	98
Ramona Pouro... 7657568	10/18 7:45	3	142 / 89	102.9	90	20	94
Randolph Kozey 0987696	10/18 7:02	3	144 / 78	101.5	74	16	97
Lynn McGlynn 6343677	10/18 6:10	0	149 / 98	98.8	87	19	95

Single patient view:

The single patient view is intended to be displayed while you are taking vitals on the current patient.

12/10/2022			12/11/2022		12/12/2022		Parameters
5:45	6:00	9:45	6:15	9:10	6:35	9:30	Selection
EWS 0	EWS 0	EWS 1	EWS 2	EWS 3	EWS 3	EWS 3	<input checked="" type="checkbox"/>
99%	99%	99%	95%	92%	92%	92%	SpO2
76	78	71	73	73	75	75	Heart Rate
122 / 80	122 / 80	122 / 80	122 / 80	122 / 80	180 / 100	180 / 100	NIBP
17	17	17	17	18	20	20	Resp Rate
99.0	99.7	102.2	102.2	102.5	100.1	98.8	Temp

Settings tab

The Settings tab enables you to edit certain device functions. It contains the following tabs:

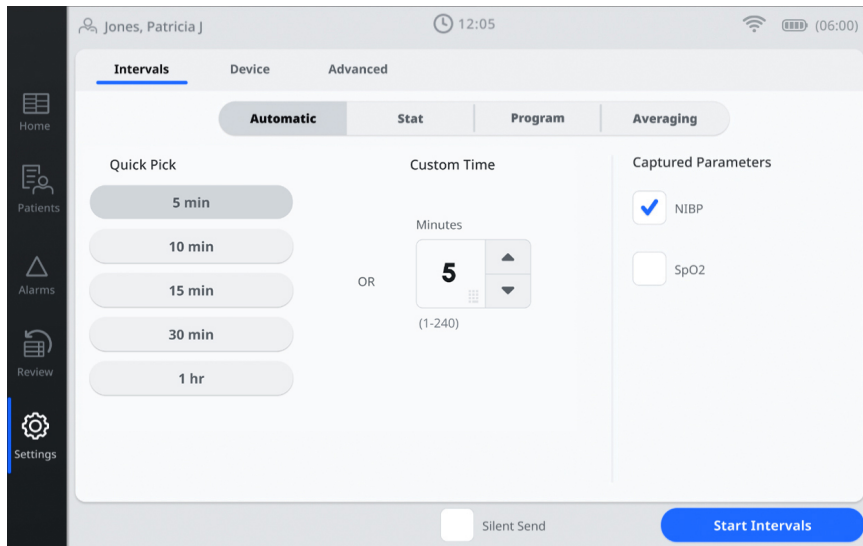

- Intervals
- Device
- Advanced (this tab is password protected and available only to authorized personnel)

Adjust screen brightness

Adjust screen brightness in the Device tab in Settings. The screen can be adjusted to 10 levels of brightness.

1. On the Settings tab, touch **Device**.
2. In the Brightness area, touch ▲ or ▼ to brighten or dim the screen or select the data field and launch a keypad to manually adjust the brightness or dimness.

Patient data management

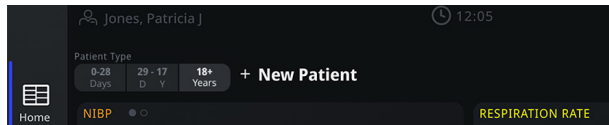

Patient data is displayed on the Home tab in the upper left. To view more detailed information, touch the patient area to access Patient Context. View patient details, update, and touch Save when done.

When the device is connected to an electronic medical record (EMR) system, patient demographics data is managed through the Patients tab. The patient's tab is displayed when the device is configured to query a patient list from the network, such as electronic medical record (EMR) system, health information system (HIS), **HL7** records, etc..

From the Patients tab, you can do the following:

- Retrieve a patient list from the network
- Search for a patient from the patient list
- Select a patient
- Add a new patient



WARNING Patient injury risk. To ensure data integrity and patient confidentiality, save readings and clear the monitor's display between patients.



WARNING Verify patient identity on the monitor after manual or barcode entry and before saving or transferring patient records. Failure to identify the correct patient can result in patient injury.

Patients tab



WARNING Patient injury risk. Verify patient identity on the monitor after manual or barcode entry and before transferring patient records. Failure to identify the correct patient can result in patient injury.

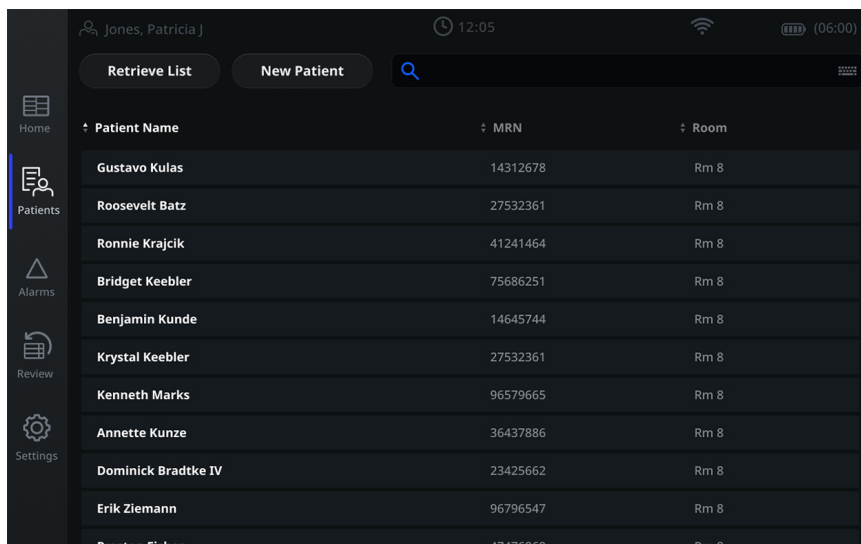

From the Patients tab screen, you can do the following:

- *Retrieve List*. Retrieve a patient list from an external network such as an electronic medical records (EMR) system, health information system (HIS), or **HL7** records list.

1. Touch the **Patients** tab. The screen appears with the **Retrieve List** and the **New Patient** buttons.
 2. If the monitor is connected to the network, touch **Retrieve List** to update the onscreen patient list. The monitor retrieves the patient list from the network.
- *New Patient.* Add a new patient.
 1. If enabled for manual patient entry, touch the **Patients** tab.
 2. Touch **New Patient**.
 3. If enabled, use a barcode scanner to scan the patient ID or touch within any field and enter patient information. Touch **OK** to save and return to the Home tab.
-  **NOTE** If enabled, you can use a barcode scanner to enter a patient ID. When the scanned ID matches a patient in the list, the scanned patient information transitions to the home screen. When the scanned ID does not match a patient in the list, the scanned number will be added to the MRN field.
4. Use the keyboard to enter the information for a new patient. Touch **OK** once information is complete.
- *Search field.* Use the keyboard to manually search for a particular patient and filter that patient from a list obtained from an external network such as an electronic medical records (EMR) system, health information system (HIS), or **HL7** records list. The example screens shows John Doe entered into the search field.

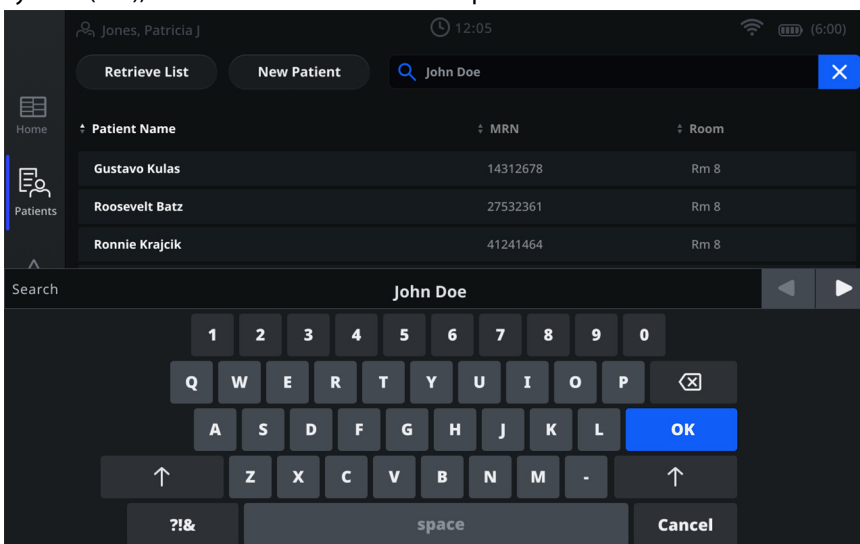

Once the list is populated, you can do the following:

- *Select a patient from the patient list:*
 1. Touch the patient's identifier (Patient name, Patient ID, or Patient location) to select a patient.

 **NOTE** You can use an optional scanner to scan in the patient ID. When the scanned ID matches a patient in the list, the scanned patient information transitions to the home screen. When the scanned ID does not match a patient in the list, the scanned number will be added to the MRN field.

 **NOTE** From the list screen, the patient data can be sorted in ascending or descending order by selecting the heading row and touching ▲ or ▼. If a sort marker does not appear in a column, touch the heading, and the ▲ appears.
 2. Once the patient information appears on the **Patient Details** screen, verify the details are correct, then touch **Save**. All patient details are editable if you're adding a completely new patient. After save, the patient information transitions to the Home tab.



NOTE If patient data is established using the data received from the EMR, the **Patient Context** screen is not editable. However, you can change the patient's age manually.



NOTE Patient Age is a required field and determines patient type (neonate, pediatric, or adult).

Patient Age Selection

- If configured, the patient's age is displayed based on the patient's date of birth received from the EMR.
- You can change the patient's age manually by touching the patient age range on the **Patient Context** screen.

Home tab without Patients Tab

If your device is configured to look up a patient from an EMR system with a patient ID, you can do the following:

- Load patient data using a patient barcode
- Define or load a new patient

Loading patient data with barcode

You can use the barcode scanner to query existing patient records and perform a name match with the Host system.



NOTE If the device is connected to the network and configured to search EMR by patient ID, the monitor can receive a patient name from patient records associated with a scanned ID number.

1. Confirm that you are on the Home tab
2. Scan the patient's barcode with a scanner or RFID reader.

The Patient ID appears on the patient area on the Home tab.

Define or load a new patient

1. If enabled for manual patient entry, touch the patients area on the home screen.
2. Touch **New Patient**.
3. Touch within any field and then type patient information.

The screenshot shows the 'Patient Context' screen with the following fields and values:

Patient Context	
Patient Details	
Last Name	Doe
First Name	John
Middle Initial	
DOB	10/25/78
Patient Age	0-28 Days, 29-17 Y, 18+ Years
MRN	8797467562

Patient Location	
Room	8
Bed	12

Buttons: Clear, Cancel, Save



NOTE If enabled, you can use a barcode scanner to enter a patient ID.



NOTE Patient Age is a required field and determines patient type (neonate, pediatric, or adult).

- If configured, the patient's age is displayed based on the patient's date of birth received from the EMR.
- You can change the patient's age manually by touching the patient age range on the **Patient Context** screen.

4. Touch **Save** to save and return to the Home tab.

Manage patient records

To review data for a single patient, select a patient from the list.

From the patient record screen, unsent patient records can be sent to the network or deleted.

1. Touch the **Review** tab. (Multiple patients screen shown)

Patient	Date /Time	MEWS	NIBP	Temp	PR	RR	SpO ₂
Bryant Beatty 7874729	10/18 12:30	1 >	122 / 80	100.5	76	17	99
Shari Tremblay 8872686	10/18 11:00	0 >	140 / 82	98.4	85	19	99
Owen Kovacek 2357265	10/18 10:20	3 >	146 / 82	103.5	135	19	96
May Bartell 9896835	10/18 9:10	0 >	130 / 86	97.9	80	25	99
Elvira Goldner 5432452	10/18 9:00	0 >	135 / 89	98.5	88	12	104
Eugene Davis 1454367	10/18 8:01	0 >	134 / 90	98.9	76	17	98
Ramona Pour... 7657568	10/18 7:45	3 >	142 / 89	102.9	90	20	94
Randolph Kozey 0987696	10/18 7:02	3 >	144 / 78	101.5	74	16	97
Lynn McGlynn 6343677	10/18 6:10	0 >	149 / 98	98.8	87	19	95



NOTE Measurements that triggered a physiological alarm are highlighted with color.



NOTE If your device is configured for Custom scoring, a column for Early Warning Scores (MEWS) appears.

2. Select patients by touching the check box next to their names.

3. Touch **Send** to transmit the records to the network or **Delete** to permanently remove the records as desired.

CAUTION Verify patient identity on the monitor after manual or barcode entry and before transferring patient records.



NOTE The  icon indicates the records have been sent to the network.



NOTE Patient measurements older than 24 hours are automatically deleted from the Review tab.



NOTE The date and time stamps on saved patient measurements adjust in response to new date and time settings.

Modifiers and manual parameters

Modifiers enable you to save additional information for the measurements for a specific patient:

- Custom modifiers are specific to a facility or a unit; custom modifiers are set up during the initial configuration requested by your facility.
- **Additional Parameters** (manual parameters) are core measurements that you can enter physically on the monitor, such as height, weight, temperature, respiration rate, and pain.

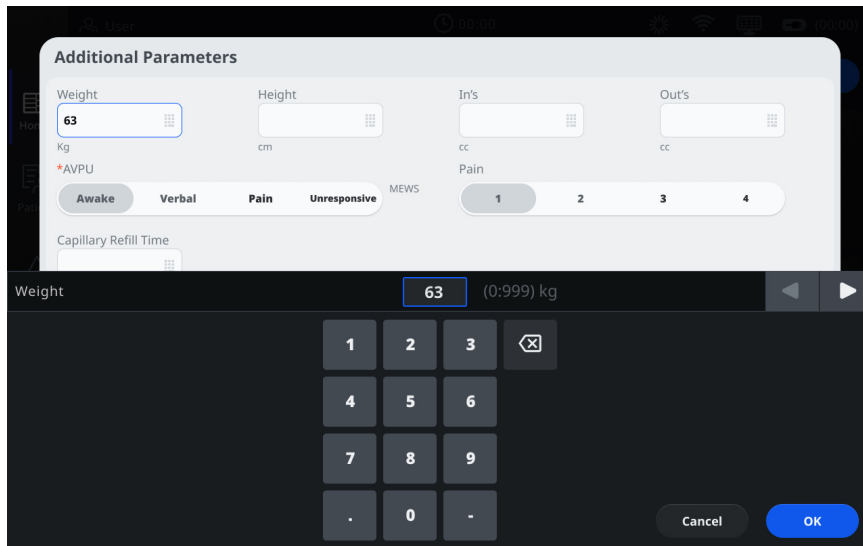

If Modifiers are not pre-configured, touching and holding a parameter frame opens the data entry keypad to make a manual entry. See "Manual entry".

If Modifiers are configured, touching and holding a parameter frame displays the modifiers screen. Touching the modifiers button (inside a parameter frame) from the home screen also displays the modifiers screen.



NOTE These actions are not available if intervals are running.

Manual entry

1. Touch and hold a parameter frame, such as NIBP.

The Modifiers and Parameters Manual Entry screen appears. If modifiers are preconfigured they can be entered on this screen.

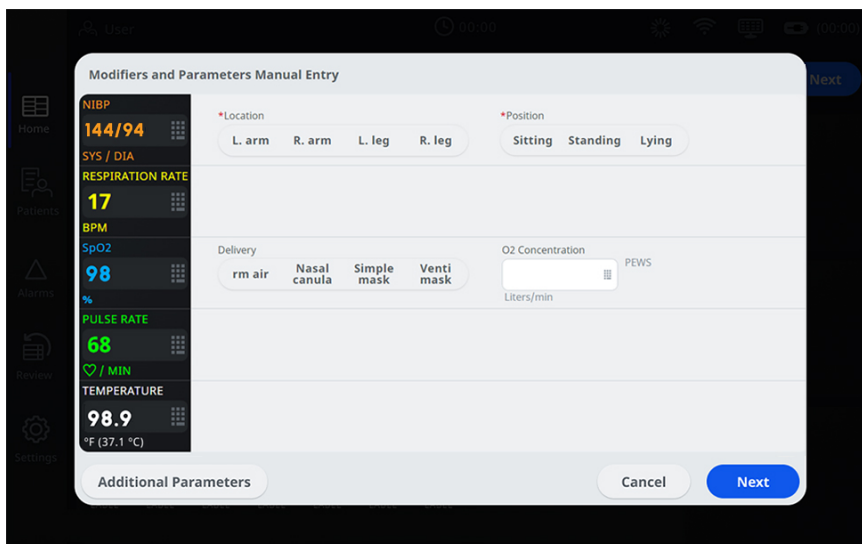

Manual input ranges for:

- SpO2 is 0-100%.
- Pulse rate is 20-250 bpm.
- Respiration rate is 0-99 BPM.
- Temperature is 68.0-110.0 °F (20.0-43.3 °C).

2. Touching and holding within the NIBP frame opens up the NIBP manual entry keypad. Manually enter the value for the parameter by touching within the field, entering the value on the keypad, and touching **OK**.
3. After all Modifiers are complete, touch **OK** or **Next**, depending on your configuration. If a dialog box appears based on your facility requirement that you enter all required fields, enter any missing values and touch **OK** or **Next** at the prompt.
4. If additional parameters are configured, access them by touching **Next**.
5. Touch **Save** to save the measurement.

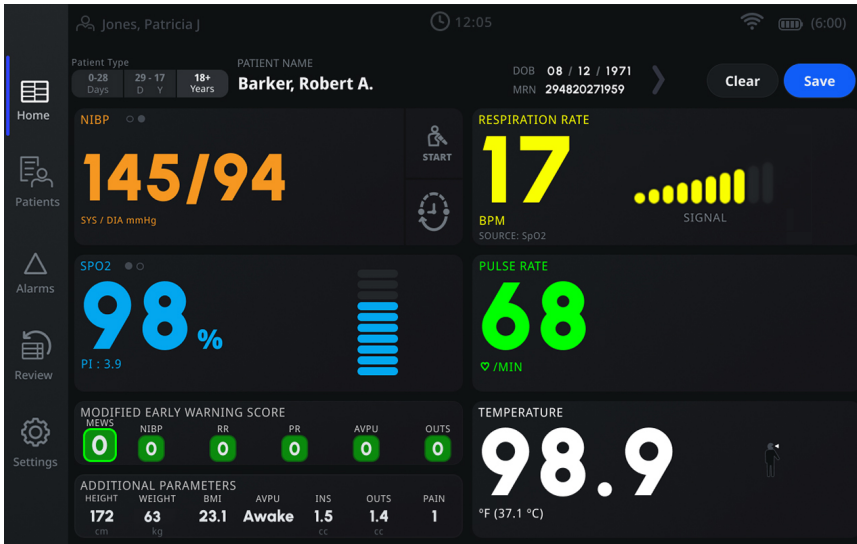

Enter additional parameters



NOTE Authorized personnel can select and configure Custom scoring and can set Manual Parameters and Modifiers.



NOTE If Manual parameters are selected, only seven parameter types appear in Additional Parameters frame on the Home screen.

1. On the Home tab, touch the additional parameters frame.

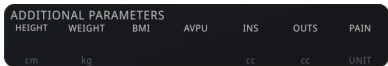

2. Select the desired parameter from the Additional Parameters screen.

Patient data management

Additional Parameters

Weight Kg
Height cm
In's cc
Out's cc

*AVPU
Awake Verbal Pain Unresponsive MEWS
Pain 1 2 3 4

Capillary Refill Time Second(s)

Modifiers Cancel OK

3. Touch a parameter, such as **Weight**, enter the data and touch **OK**.

Additional Parameters

Weight Kg
Height cm
In's cc
Out's cc

*AVPU
Awake Verbal Pain Unresponsive MEWS
Pain 1 2 3 4

Capillary Refill Time

Weight (0:999) kg

1 2 3 [X]
4 5 6
7 8 9
· 0 -

Cancel OK

4. Touch **Modifiers** to manually enter additional information on the Modifiers screen. Touch the desired modifiers and touch **OK** to commit the entry.

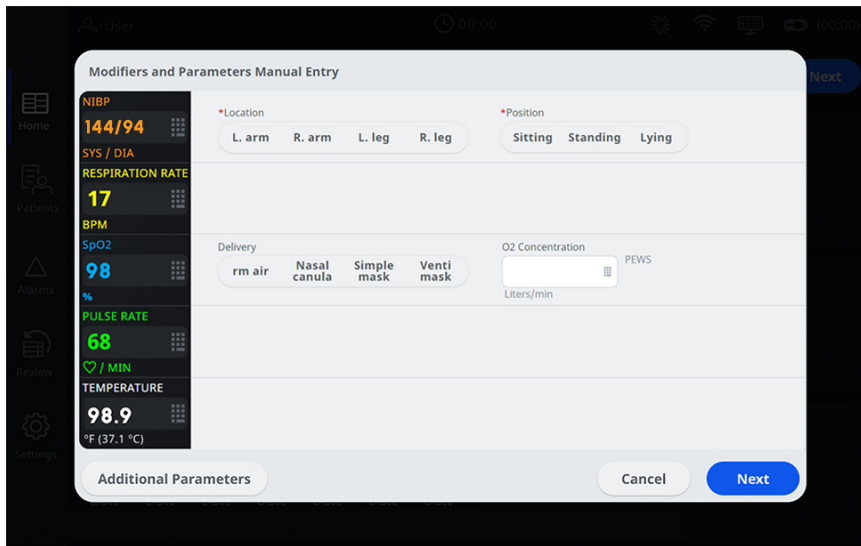

5. If there are multiple parameters touch **Next** until the dialog screens close and you're back on the home screen.



NOTE Ensure that the current patient ID is correct before saving. If **SureTemp** temperature or NIBP readings are in progress the manual entry keypad is disabled.

6. Touch **Save** to save the data.

Custom scoring [Facility Warning Score]



WARNING Risk to patient safety. Custom scores and messages serve as guides to your facility's protocols; *do not substitute custom scores for patient physiological alarms*. Appropriate alarms settings must be set and maintained to ensure patient safety.

Custom scoring enables you to configure specific parameters, based on your institution's practice standards, that calculate scores for patient monitoring. These scores generate messages regarding the patient status, based on the parameters chosen. These messages are provided only as reminders. Use the Welch Allyn Product Configuration Tool to define custom scoring protocols.

Enter Early warning scores



NOTE Authorized personnel can select and configure Custom Early Warning Scores and can set Manual Parameters and Modifiers.



NOTE The device can accommodate up to 6 custom EWS and up to 20 customizations with manual parameters and/or modifiers. These customizations are defined in the configuration file.

Patient data management

1. On the Home tab, touch within the custom score assessment frame to see the Custom Scores Selection screen. In the following screen example, Modified Early Warning Score (MEWS) is the custom score assessment frame.

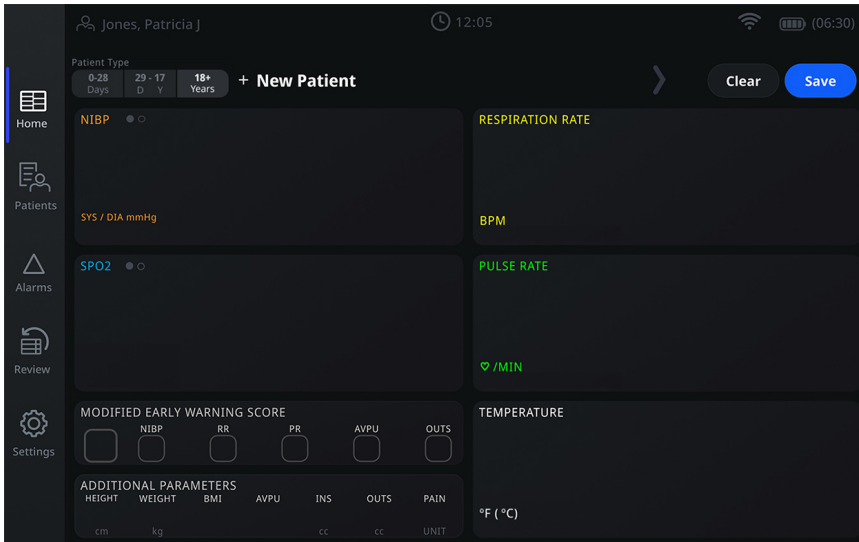

2. On the Custom Score Selection screen, touch the radio button next to an available custom score. The necessary parameters for that custom score are shown to the right. In the following screen example, MEWS is the pre-selected custom score. Touch the modified early warning score frame to select a custom score (if there are multiples) and enter the required information. Parameters with a check mark indicate completed defined parameters for the selected custom score. Incomplete parameters will not have a check mark and will result in a partial score.

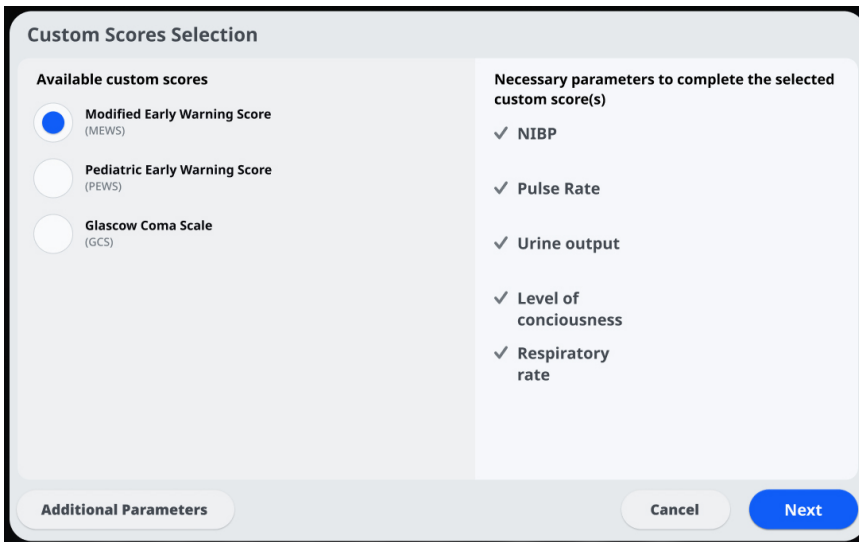

3. Enter additional parameter values. Touch **Next** or select the desired parameter from the Additional parameters screen.

4. If there are multiple parameters in the configurable Custom Scores Additional Parameters screen, touch **Next** until you reach the final screen.
5. Take note of the risk scores, facility messages, and required responses and then touch **OK**.

6. Touch **SAVE** to save the data and clear the screen.



Partial early warning scores



NOTE Authorized personnel can select and configure custom Early Warning Scores and can set Manual Parameters and Modifiers.

When custom scores are configured and you are unable to capture all the required vitals, the **Connex 360** monitor will calculate a partial early warning score using the available information. The summary screen will reflect the vitals entered.

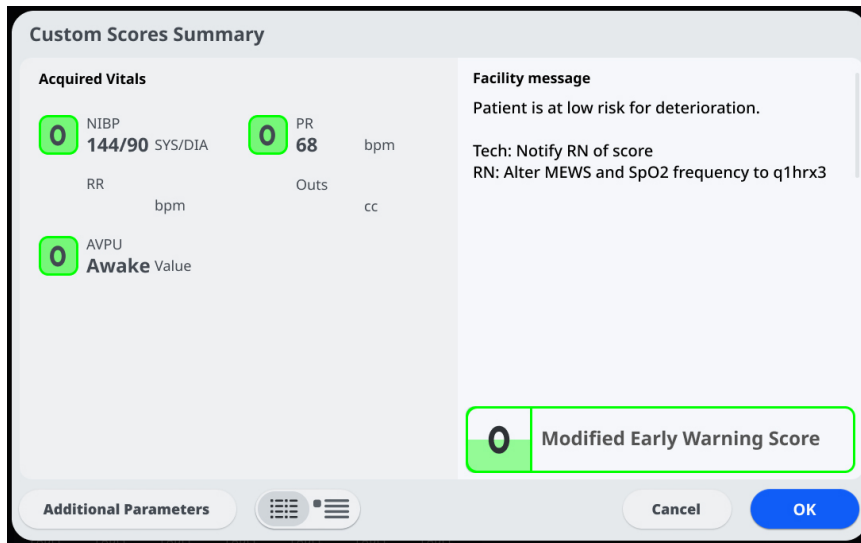

On the home screen, the MEWS icon reflects that only some of the required vitals were used in the calculation. The parameter frame summarizes the captured vitals.



Welch Allyn Product Configuration Tool

The Welch Allyn Product Configuration Tool is a web-based tool. The configuration tool allows you to choose the device settings for your facility. For more information, contact your sales representative.

Advanced settings

Consult the **Connex 360 Service manual** for Advanced settings.

Alarms

The monitor presents physiological alarms and technical alarms. Alarm controls are enabled once automatic, stat or program intervals begin. When intervals are active, physiological alarms occur when vital sign measurements fall outside of set alarm limits.

If the alarm controls are disabled, the alarm log is maintained on the monitor for 14 days.



 **NOTE** See the Service manual for further details about SpO2 and RRp alarm condition delays.

 **NOTE** The three modes of data communication—USB, Ethernet, and IEEE 802.11—are not intended for real-time alarms.

Vital sign summary view

At the top of the Alarms tab is a summary view of the core vital signs. You cannot control any of the core vital sign parameters from the summary view.

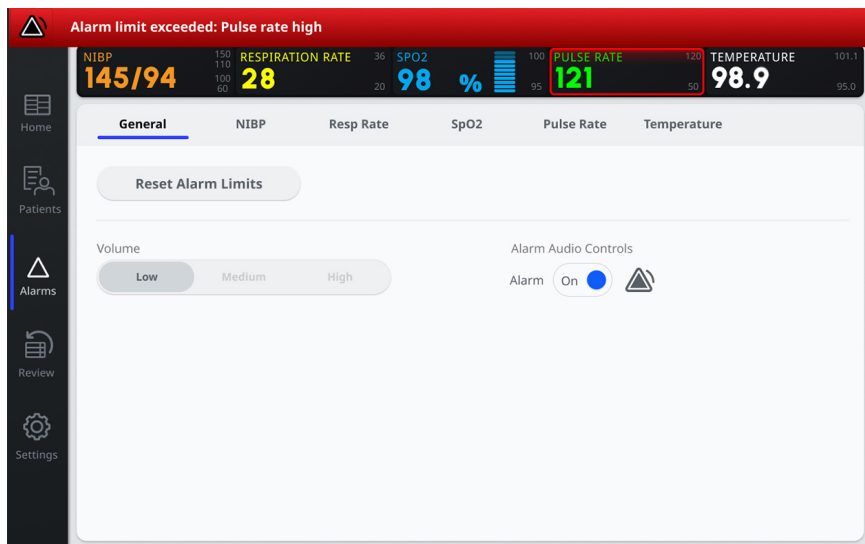

Alarm system logging

The monitor has a capacity of at least 1000 events. The monitor logs the following the events:

- alarm settings when the monitor is turned on
- any changes to alarm settings
- start, stop, and pause dates and times of alarm signals
- priority of alarm conditions

If the alarm controls are disabled, the alarm log is maintained on the monitor for 14 days.

After the alarm system experiences a total loss of power, the current log files will be saved but no new log files will be created until power is restored.

The alarm system keeps 14 days of the alarm log and will erase the oldest day entry if it reaches 14 days of capacity.

The alarm system discards the oldest data when the log becomes full.

Alarm limits

Default alarm limits are determined by the facility and are incorporated in the configuration file. Only authorized facility personnel can edit these limits.

Alarm reminder signal

An alarm reminder signal appears for all alarms if the global alarm audio has been paused or turned off. The reminder signal interval is the same as the alarm interval with which it appears.

Alarm types

Type	Priority	Color	Alarm audio tone
<ul style="list-style-type: none"> • NIBP , SpO2, pulse rate, or respiration rate limit exceeded • Some technical alarms 	High	Flashing red	10-pulse tone
<ul style="list-style-type: none"> • Some technical alarms 	Medium	Flashing amber	3-pulse tone
<ul style="list-style-type: none"> • Temperature limit exceeded • Some technical alarms 	Medium	Amber	2-pulse tone or 1-pulse tone
<ul style="list-style-type: none"> • Some technical alarms 	Very low	Cyan	

Alarm notification locations



WARNING Patient injury risk. If you are relying on visual alarm notifications, maintain a clear line of sight with the monitor and/or Nurse Call. Set the volume as needed considering the environment and ambient noise levels.



WARNING Patient injury risk. Do not set the alarm parameters to extreme levels. Setting extreme parameters could render the alarm system useless, causing the potential for patient injury.

Nurse Call

When the Nurse Call cable is connected and Nurse Call has been enabled, the monitor immediately notifies the Nurse Call system when an alarm occurs. Nurse Call notification settings are specified in the configuration settings.

Home tab



Home tab notifications

Notification	Description
Device Status area	<p>The area changes color and displays a message with an accompanying status icon or button. If the alarm tone is in a pause interval, a timer countdown appears.</p> <p>If multiple alarms and information messages are active, the Device Status area shows the highest priority alarm. If the alarms are equal in priority, the most recent alarm message appears. The Device Status area will auto-scroll through multiple alarms or you can cycle through the messages for each active alarm.</p>
Parameter frame	<p>The frame of the parameter brick flashes in the color of the alarm priority. Touch this area to pause or turn off an alarm audio tone. Visual indicators and Nurse Call notification will persist during an audio paused condition.</p>
Alarm Limit control	<p>The icon in this control indicates the status of the alarm limit settings. Red and amber icons indicate measurements that have exceeded alarm limits.</p> <p>Touch this control to navigate to a parameter-specific tab where you can modify alarm limit settings.</p>

Icons on the Home tab

Icons in the parameter frames





The icons in the parameter frames indicate alarm notification settings. Alarm controls are enabled once automatic, stat or program intervals begin. When alarm limits are set and running, the icons will be gray until an alarm occurs. Then, the icons will change color to indicate the priority of the alarm. Red icons represent high priority alarms, and amber icons represent medium or low priority alarms.

Icon	Name and status
	<p>Alarm off.</p> <p>No visual or audio alarms or Nurse Call notification will occur for this parameter.</p>
	<p>Alarm on.</p> <p>Audio and visual notifications and Nurse Call notifications are enabled provided that the nurse call cable is connected to the monitor and configured for use.</p>
	<p>Alarm audio off.</p> <p>Only visual notifications, including Nurse Call, will occur provided that the nurse call cable is connected to the monitor and configured for use.</p>

Icon	Name and status
	Alarm audio paused. The icon remains until the paused time counts down to 0. Authorized personnel can configure the secondary audio pause time.

Icons in the Device Status area

The icons in the Device Status area are black and white, but the background area changes color to indicate the alarm priority. Messages accompany these icons. These icons can be controls or status indicators.

Icon	Name and status
	Alarm active. One or more alarms are active. Touch this icon to pause or turn off the audio tone.
	Alarm audio off. Audio signals are disabled, but alarm limits and visual alarm signals remain active.
	Multiple alarms toggle. Touch this icon to cycle through the messages for each active alarm.
	Alarm audio paused. The default audio pause alarm duration is 1 minute. The icon remains until the paused time counts down to 0. Authorized personnel can only configure this parameter using the Welch Allyn Product Configuration Tool.

Reset [pause or turn off] audio alarms



Audio alarm characteristics

- After you reset an audio alarm, some tones do not return, but others return after a pause interval if the condition that caused the alarm persists.
- If a new alarm condition occurs during a pause interval, a new audio tone occurs.

Pause or turn off an audio alarm



1. In the Device Status area, touch .
 - Visual indications remain in the parameter frame until the condition is corrected or until the next measurement is taken.

- In the Device Status area, if the icon changes to  and the message remains, the timer counts down and the audio tone returns after a pause interval. You can touch  again to restart the timer. If you responded to an NIBP alarm and multiple NIBP limits have been exceeded, the first audio tone and message go away, but another NIBP limit message shows with a countdown timer. A new NIBP audio tone sounds after the countdown unless you touch  to dismiss each remaining NIBP limit message.
2. If multiple alarms are active, a multiple alarm toggle will appear in the Device Status area. Respond to multiple alarms as follows:

- Touch  in the Device Status area. (See note below.)
- Read the alarm message for the second alarm.

- Touch .
- Continue to touch multiple alarm toggle buttons and to reset tones until you have read all of the messages.



NOTE The multiple alarm toggle button will display the number of active alarms inside the alarm icon. A set of dots indicating the display order of alarms from highest (left) to lowest (right) priority (as well as the most recent in the case of multiple alarms of the same priority) will appear below it.

Adjust vital sign alarm limits



NOTE Alarm limits may have been set based on the date of birth (DOB) of the patient.



NOTE Alarm limits can be changed.

You can adjust vital sign alarm limits or turn off alarm limit checking for individual parameters.



WARNING Alarm limits are user adjustable. All alarm limit settings should take into account the patient's condition and acute care needs. Appropriate alarm limits should be set accordingly for each patient.



CAUTION Loss of power will cause the monitor to return to facility-configured default settings. Because alarm limits reset to facility-configured default settings on power loss, you must set alarm limits appropriate for each patient.

1. On the **Home** tab, touch the alarm limits control in the selected parameter frame. For example, to adjust the

NIBP alarm limits, touch .

2. Adjust vital sign alarm limits.
 - To adjust a limit: Touch ▲ or ▼ or touch the keypad to set the desired upper and lower alarm limits.

Alarms

- To turn alarm limits off or on for the vital sign: Touch   or  . This button toggles to display the current alarm state.

If you turn off alarm limit checking for a vital sign, no visual or audio alarm signals will occur for those



limits. If alarm limit checking is off, the icon changes to  on the **Home** tab in the parameter frame.

Reset alarm limits to the factory default settings



NOTE Only facility-authorized personnel are able to reset alarm limits to factory default settings. All users are able to reset alarm limits to the facility-configured default settings.





NOTE Alarm limits can be reset to facility-configured default settings on power up for new patients.

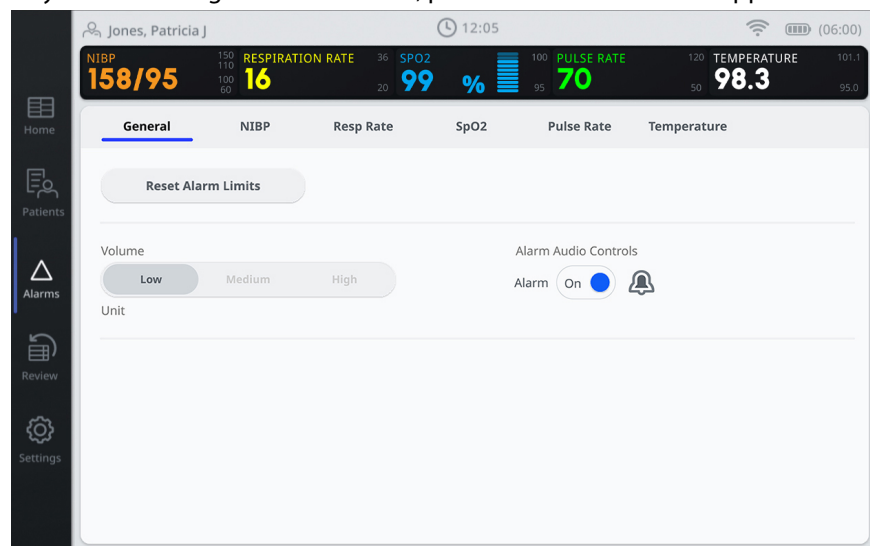

WARNING Alarm limits are patient-specific. For alarms to function properly, you must set or verify alarm limits appropriate for each patient. Each time the monitor is powered on, you must check that the alarm settings are appropriate for your patient before you start monitoring.

As you are working in the Alarms tab, parameter measurements appear across the top of the tab.



1. Touch the **Alarms** tab.
2. Touch **Reset alarm limits** to set all upper and lower alarm limits and their On and Off states to the facility-configured default settings.
 -  **NOTE** Touching Reset alarm limits on the Alarms tab resets the alarm limits for the current monitoring session only.
3. Alarm limit values display while intervals are running.
 - When an alarm is disabled, alarm limit values are displayed on the Home tab within the alarm buttons. The alarm icon changes to a crossed-out triangle.
 - When an alarm is enabled, alarm limit values are displayed on the Home tab within the alarm buttons. The alarm icon is a bell.
4. Alarm audio control is configurable. When alarm audio controls are off, all selected alarm icons appear as crossed out bells.

Modify audio alarm notification

You can modify the volume of all audio alarms.



WARNING The alarm volume should be loud enough for you to hear it from where you are. Set the volume considering the environment and ambient noise levels.

As you set parameters on the Alarms tab, measurements appear across the top of the tab.

1. Touch the **Alarms tab**. The horizontal General tab appears.
2. Touch the tab for each parameter to modify the audio alarm notifications for that parameter.
 - To adjust a limit, touch ▲ or ▼ or touch the keypad to set the desired upper and lower alarm limits.
 - To turn audio alarms on or off, select **Alarm audio on** or **Alarm audio off**.

If you turn off audio alarms, visual alarm signals still occur in the Device Status area and on the Home tab in parameter frames.



The  in the Device Status area indicates alarm audio turned off, and a similar bell will appear in



the parameter frames . If an alarm condition occurs, the bell will be red or amber in the alarming



frame, according to the priority of the alarm, as shown here:

- To modify the volume of audio alarms: Select the volume button next to either **High**, **Medium**, or **Low**.

An audio tone sounds briefly to indicate the volume level.



NOTE Periodically test the speaker by selecting different speaker volumes and listening for the different tones.

3. To reset alarm settings to the facility-default configuration, touch **Alarm reset**.

Alarm messages and priorities

The following table lists the physiological alarm messages and their priorities.

See "Troubleshooting" for technical alarm messages.

Physiological alarms

Alarm messages	Priority
Alarm limit exceeded. NIBP systolic HIGH.	High
Alarm limit exceeded. NIBP systolic LOW.	High
Alarm limit exceeded. NIBP diastolic HIGH.	High
Alarm limit exceeded. NIBP diastolic LOW.	High
Alarm limit exceeded. NIBP MAP HIGH.	High

Alarm messages	Priority
Alarm limit exceeded. NIBP MAP LOW.	High
Alarm limit exceeded. Pulse rate HIGH.	High
Alarm limit exceeded. Pulse rate LOW.	High
Alarm limit exceeded. SpO2 HIGH.	High
Alarm limit exceeded. SpO2 LOW.	High
Alarm limit exceeded. Respiration Rate HIGH.	High
Alarm limit exceeded. Respiration Rate LOW.	High
Alarm limit exceeded. Temperature HIGH.	Medium
Alarm limit exceeded. Temperature LOW.	Medium

Nurse Call

The monitor can be connected to a Nurse Call system through a cable that connects to the Nurse Call connector.

When the Nurse Call cable is connected and Nurse Call is enabled, the monitor immediately notifies the Nurse Call system when any alarm condition occurs that exceeds the preset threshold. The Nurse Call system is also synchronized with the alarm parameter frame and audible alerts on the monitor.

Nurse Call thresholds are set in the configuration settings.

To connect the monitor to a Nurse Call system, you must have a cable that has been adapted to your Nurse Call system (REF 6000-NC), rated 24V at 500mA maximum. For ordering information, see Approved Accessories in the Appendix.



WARNING Do not rely exclusively on Nurse Call for patient monitoring. Although the Nurse Call option enables remote notification of an alarm condition, it is not intended to replace appropriate bedside patient monitoring by trained clinicians.



NOTE When a patient alarm occurs, touching the alarm icon in the Device Status area pauses the alarm tone for the default setting of 1 minute.

Patient monitoring

You can configure the monitor to take automatic NIBP and SpO2 measurements at consistent intervals. See "Start Averaging intervals" for the instructions to choose a preconfigured interval program that enables you to record the patient's average NIBP and optional Pulse Rate readings.

The following sections describe the parameters available on the device, how to modify settings and alarm limits for those parameters, and how to take parameter measurements.

Before focusing on each parameter, each section addresses features that generally apply to the parameters on your device: custom modifiers and manual overrides.

Required parameters

If a parameter is required and is configured on your monitor per your facility requirement, enter all required data. If fields are left blank, a dialog screen appears prompting you to confirm that you want to leave the required fields empty. Touch **Next** or **OK** to commit the data and move to the next screen. Or touch **Cancel** to revert the changes.

The screenshot shows a dialog box titled "Additional Parameters". It has four input fields: "Weight" (Kg), "Height" (cm), "In's" (cc), and "Out's" (cc). Below these is a section for "*AVPU" with four radio buttons: "Awake", "Verbal", "Pain", and "Unresponsive". To the right of this is a section for "MEWS" with four radio buttons: "1", "2", "3", and "4". Below that is a field for "Capillary Refill Time" (Seconds). At the bottom of the dialog are three buttons: "Modifiers", "Cancel", and "OK".

 **WARNING** Patient injury risk. Many environmental variables, including patient physiology and clinical application, can affect the accuracy and performance of the monitor. Therefore, you must verify all vital signs information before treating the patient. If there is any question about the accuracy of a measurement, verify the measurement using another clinically accepted method.

 **WARNING** Patient injury risk. During defibrillation, keep discharge paddles away from monitor sensors, and other conductive parts in contact with the patient.

Intervals

 **WARNING** Patient harm risk. Do not use intervals on neonates out of your hearing range. Verify that the audio can be heard from where you intend to be.

The monitor can capture NIBP and SpO2 measurements based on the intervals you choose on the Settings tab.

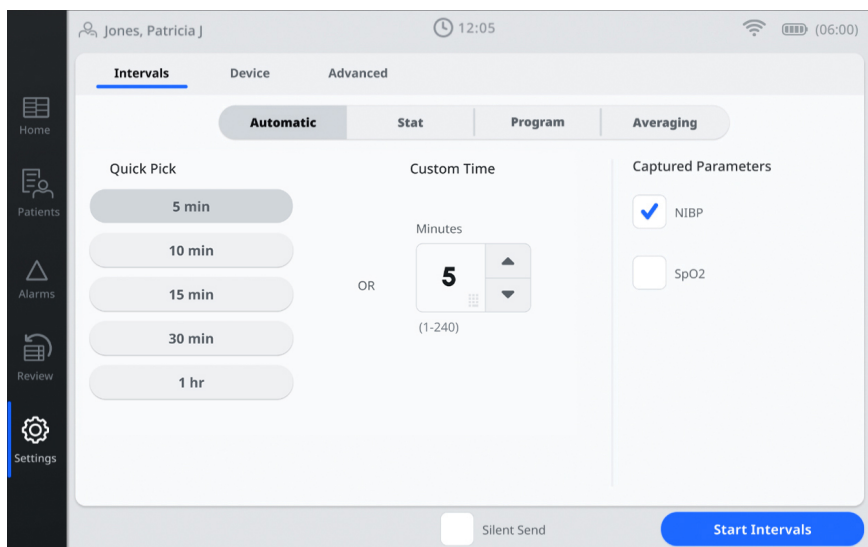

 **NOTE** If configured with a MasimoSpO2 and a **RRp** license, the monitor also measures respiratory rate through photoplethysmogram analysis of SpO2 (**RRp**).

 **NOTE** To disable the audible confirmation of intervals data sent: Select Silent Send by touching the check box next to Silent Send.

In Settings, the Intervals tab provides all intervals features.

You can do the following from the Intervals tab:

- Configure intervals
- Start and stop intervals

Automatic intervals

You can configure the monitor to take automatic consistent intervals of:

- NIBP and SpO2 measurements
- NIBP measurements
- SpO2 measurements

 **NOTE** An alarm does not turn off intervals. Subsequent automatic measurements continue to occur as scheduled.

Start Automatic intervals

1. Place the proper cuff around the patient's bare upper arm.



2. On the Home tab, touch . The horizontal Intervals tab on the Settings tab appears.

3. Touch **Automatic**.

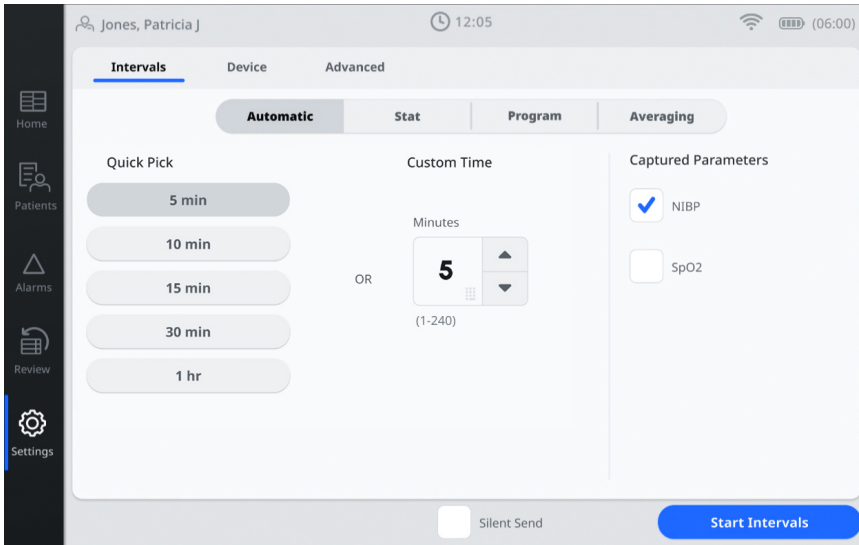

4. Select a quick pick of either 5 min, 10 min, 15 min, 30 min, or 1 hr interval, use the keypad, or use ▲ or ▼ to enter the length of time between NIBP measurements for custom entry.
Touch the check-box to collect the desired parameters. Choose NIBP, SpO2, or both.
5. Touch **Silent Send** to save intervals without an audible indication.
6. Touch **Start Intervals**.

Program intervals

The monitor can accommodate up to six custom programs. One program can be defined on the device to meet patient-specific needs, and five customizable programs can be defined to accommodate facility-specific needs.

The monitor contains an Advanced tab that provides password-protected access to the monitor's Advanced settings, enabling nurse administrators, biomedical engineers, and/or service engineers to configure facility-specific custom programs. If your facility has not configured the remaining custom programs, contact your administrator or consult your facility's protocols and standards.

The numbers below the program names indicate the length of time between each interval in the cycle and the number of cycles to be completed for each interval.

Start program intervals



NOTE To use Program Intervals or to select between different programs set up Intervals Programs in **Advanced settings > Parameters > Program**. However, Program 6 can be adjusted from within the settings tab.

1. Place the proper cuff around the patient's bare upper arm.



2. Within the Home tab of the NIBP frame, touch .
The horizontal Intervals tab on the Settings tab appears.

3. Touch **Program**.

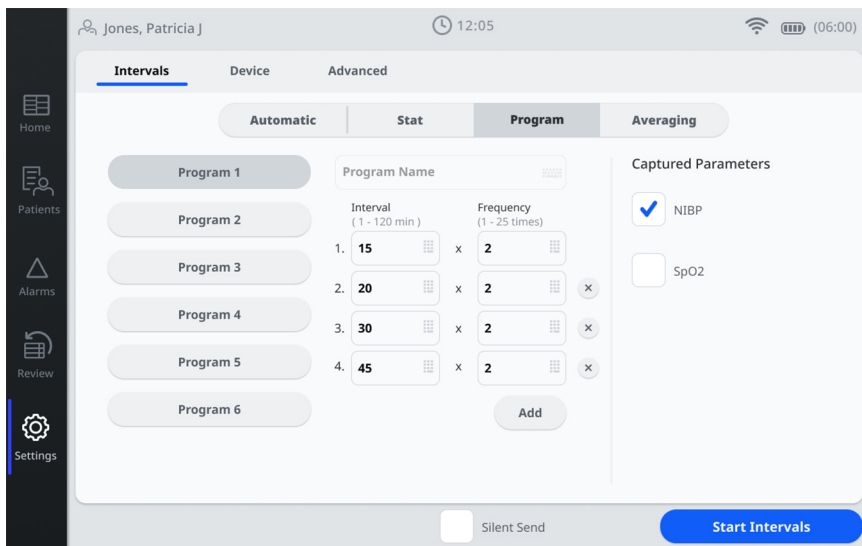

The configured Program screen appears with the available programs and the interval between measurements displayed to the right of the selected program.

4. Touch the program you want to use.
5. If you want to change the Program 6 interval, use the keypad to enter the new interval.
6. To add another interval and frequency to Program 6 touch **Add**.
7. Touch **Start Intervals**.

Averaging intervals

The averaging interval program enables you to record the patient's average NIBP and optional PR readings. The interval program runs until each of the configured readings has successfully completed.

Start Averaging intervals



NOTE PULSE RATE averaging cannot be calculated without NIBP averaging.

1. Place the proper cuff around the patient's bare upper arm.



2. On the Home tab, touch .
The horizontal Intervals tab on the Settings tab appears.

3. Touch **Averaging**.

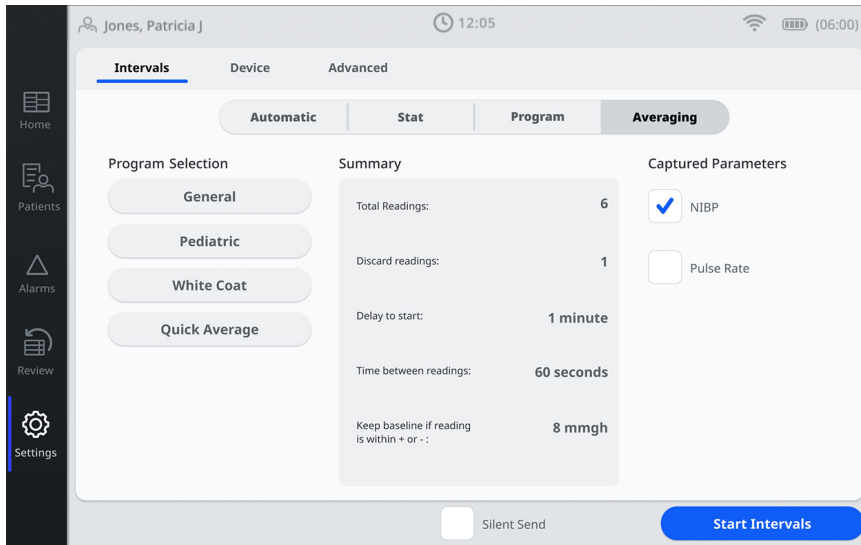

The preconfigured Program screen appears with the available programs and the configuration details of the averaging program displayed to the right of the program.

4. Touch the program you want to use. For example, touch **White coat**.
5. Touch the parameters to capture.
6. Touch **Silent Send** to save the intervals without an audible indication.
7. Touch **Start Intervals**.

The Program name appears on the Home tab, along with the averaged reading as the readings occur.



Stat intervals

You can configure the monitor to take NIBP measurements continuously.

When you select Stat on the Intervals tab in Settings, the monitor takes repeated NIBP measurements for 5 minutes, starting a new cycle each time the cuff deflates below safe venous return pressure (SVRP) for 2 seconds.



WARNING Patient injury risk. If you use Stat mode repeatedly, periodically observe the patient's limb to ensure that circulation is not impaired and that the cuff remains in place. Prolonged impairment of circulation or improper cuff position can cause bruising.



NOTE Touch **STOP** to stop intervals. To restart intervals, reselect the Stat tab.

Start Stat intervals

1. Place the proper cuff around the patient's bare upper arm.



2. On the Home tab, touch . The Intervals screen on the Settings tab appears.

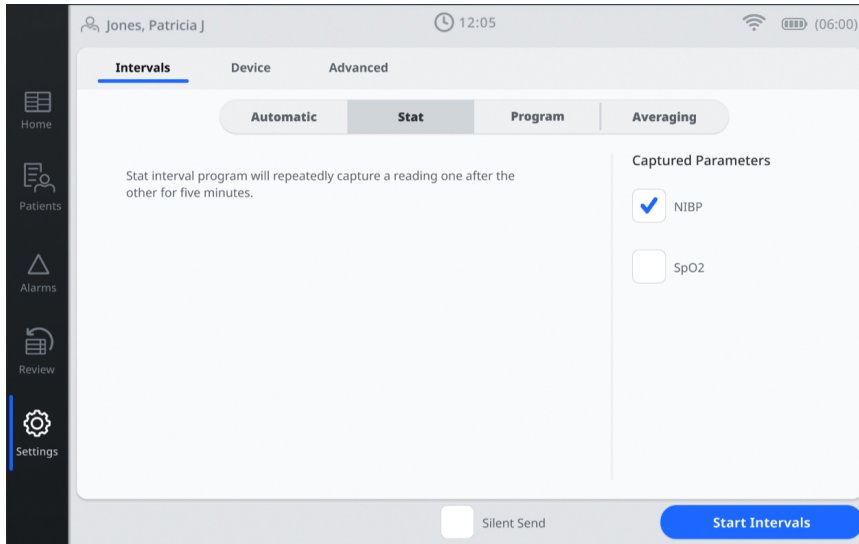

3. Touch **Stat**.
4. Touch the parameters to capture.
5. Touch **Silent Send** to save the intervals without an audible indication.
6. Touch **Start Intervals**.

NIBP

Set the cuff inflation target



NOTE To set the default cuff inflation target for each type of patient also see the Specify advanced NIBP settings instructions within the "Advanced settings" section.

1. On the **Settings** tab, touch **Settings**.
2. Touch the horizontal **Parameters** tab.

3. In the NIBP Cuff Inflation Targets area, touch ▲ or ▼ or use the keypad entry to adjust the NIBP Cuff Inflation Targets pressure higher or lower for each of the patient types.

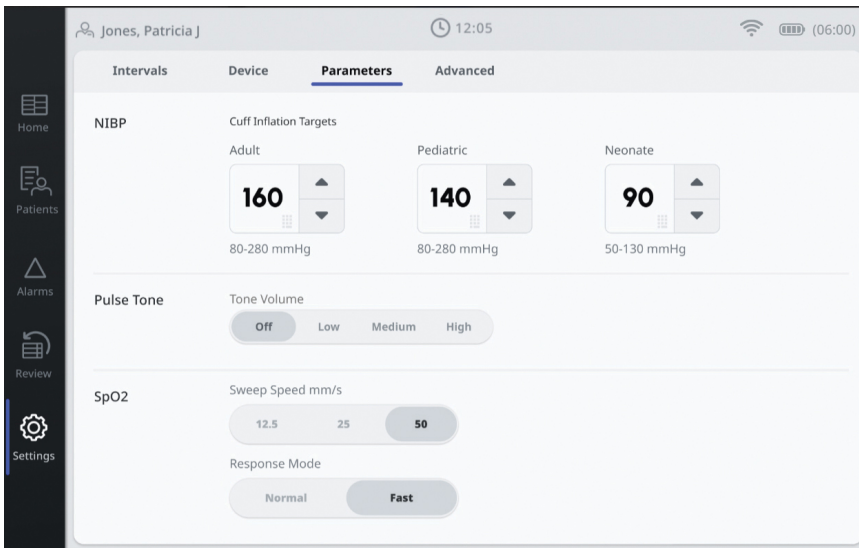

















Configure NIBP alarms with intervals active

1. Touch the Alarms tab.
2. Touch the NIBP horizontal tab.
3. Using either the keypad or ▲ or ▼, enter the desired upper and lower alarm limits for systolic and diastolic measurements, and MAP calculation.
4. Touch the Home tab.
The new alarm settings display in the Alarm Limit control button.

NIBP measurements

The NIBP measures noninvasive blood pressure and pulse rate.

-  **WARNING** Patient injury risk. Do not install luer connectors on blood pressure tubing. Using luer connectors in manual or automated blood pressure systems creates the risk of inadvertent connection to intravenous (IV) tubing, which can introduce air into the patient's circulatory system.
-  **WARNING** Do not apply cuff to areas on patient where skin is delicate or damaged. Check cuff site frequently for irritation.
-  **WARNING** NIBP readings may be inaccurate for patients experiencing moderate to severe arrhythmia.
-  **WARNING** Inaccurate measurement risk. Pulse rate measurements generated through the blood pressure cuff or through the SpO2 sensor are subject to artifact and might not be as accurate as heart rate measurements generated through ECG or through manual palpation.
-  **WARNING** Use caution when measuring blood pressure using oscillometric blood pressure devices in severely ill neonates and pre-term infants because these devices tend to measure high in this patient population.
-  **WARNING** Patient injury risk. Inaccurate measurement risk. Do not place the cuff where it can disturb proper circulation. Do not place the cuff on any area where circulation is compromised or on any extremity used for intravenous infusions.
-  **WARNING** Patient injury risk. Do not place the cuff on the arm on the same side of a mastectomy. If necessary, use the femoral artery in the thigh to take a measurement.

-  **WARNING** Possible measurement error. Use only Baxter approved blood pressure cuffs and accessories; substitution may result in measurement error.
-  **WARNING** Inaccurate measurement risk. Minimize cuff movement and arm motion during readings. Excessive movement may alter readings.
-  **WARNING** Inaccurate measurement risk. Properly position the blood pressure cuff to ensure blood pressure accuracy.
-  **CAUTION** Inaccurate measurement risk. Do not use an SpO2 sensor and a blood pressure cuff simultaneously on the same limb. Doing so may cause a temporary loss of pulsatile flow, resulting in either no reading or an inaccurate SpO2 or pulse rate until the flow returns.
-  **CAUTION** Inaccurate measurement risk. Only use the cuff when the artery index marker falls within the printed range indicated on the cuff; otherwise, erroneous readings will result.
-  **CAUTION** Inaccurate measurement risk. Any external compression of the blood pressure hose or cuff may cause system errors or inaccurate measurements.
-  **CAUTION** Inaccurate measurement risk. Ensure an airtight seal at all connection points before use. Excessive leaking may affect readings.
-  **CAUTION** Inaccurate measurement risk. The performance of the automated sphygmomanometer can be affected by extremes of temperature, humidity, or altitude.
-  **CAUTION** The Mean Arterial Pressure (MAP) is a calculated reading that yields an approximate value.

Located in the upper-left corner of the Home tab, the NIBP frame contains data and features relevant to noninvasive blood pressure measurement.

NIBP measurement display

The frame displays systolic and diastolic measurements.

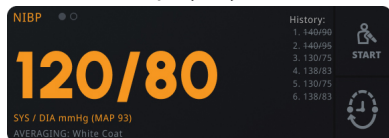

Authorized personnel can configure the default view in Advanced settings. The last NIBP measurement remains on the screen until a new measurement is started or until you touch **Save** or **Clear**.

If any NIBP measurement is out of range or cannot be determined, the NIBP frame shows a "++" or "--" instead of the numeric measurement. All other NIBP parameters display no values.

View indicator

Touch the NIBP frame to toggle between views.

Buttons

Use the buttons on the right side of the frame to perform different tasks.

Technical alarms and NIBP measurements

A technical alarm stops any NIBP measurement.

Steps to take a NIBP measurement

1. Roll up the patient's sleeve and place the cuff on a bare upper arm.
2. Use the range indicator on the cuff to select the proper size cuff. If two sizes fit the patient, use the larger one.

3. Place the artery marker over the brachial artery.
4. Apply the cuff snugly. Allow room for no more than two fingers.
5. Once the cuff is placed, allow the patient to sit quietly for 5 minutes.
6. Do not talk to the patient while taking the blood pressure reading. Ask the patient to relax as much as possible.
7. Support the patient's back and feet during the measurement. Keep legs uncrossed while the patient is comfortably seated.
8. Keep the patient's upper arm at heart level and passively support the lower arm.
9. Keep the arm still during the measurement cycle.

For additional guidance addressing best practices for taking blood pressure measurements, see [Tips for Taking Accurate Blood Pressure Readings](#) on the Baxter website.

NIBP cuffs



WARNING Patient injury risk. Use only blood pressure cuffs and hoses listed as approved accessories to ensure safe and accurate NIBP measurements.



WARNING Patient injury risk. Never use an adult or pediatric monitor setting or cuff for an NIBP measurement on a neonatal patient. Adult and pediatric inflation limits can be excessive for neonatal patients, even if a neonatal cuff is used.



WARNING Patient injury risk. The decision to use the device and accessories on pregnant or pre-eclamptic patients is at the discretion of the trained clinician using the equipment.



CAUTION Correct sizing of the blood pressure cuff is important for accurate blood pressure readings. A cuff that is too small might provide false high readings, while a cuff that is too large might provide false low readings.

The monitor uses the oscillometric method to determine blood pressure; therefore, if the cuff extends to the antecubital fossa (bend in the elbow), you can still acquire an accurate blood pressure reading.

If you use a single tube NIBP cuff, you can take only a step blood pressure measurement. The monitor will automatically default to StepBP.

Select a cuff

Before taking an NIBP measurement, follow these steps to select the appropriate cuff for the patient.

1. Measure the circumference of the patient's bare upper arm, midway between the elbow and shoulder.
2. Choose the appropriate cuff size based on the circumference measurement. If the circumference of the patient's arm falls between two cuff sizes, use the larger cuff size.
3. Wrap the cuff around the patient's bare upper arm and verify that the artery index marker lies somewhere between the two range markings on the cuff.

Cuff measurements

The following tables provide measurements for blood pressure cuffs.

One-piece cuff measurements

Cuff Size	Circumference (cm)	Circumference (in)
Infant	9.0 – 13.0	3.5 – 5.1
Small child	12.0 – 16.0	4.7 – 6.3
Child	15.0 – 21.0	5.9 – 8.3

Cuff Size	Circumference (cm)	Circumference (in)
Small adult	20.0 – 26.0	7.9 – 10.2
Adult	25.0 – 34.0	9.8 – 13.4
Large adult	32.0 – 43.0	12.6 – 16.9
Thigh	40.0 – 55.0	15.7 – 21.7

Neonatal soft disposable cuffs with NeoQuik connectors

Cuff Size	Circumference (cm)	Circumference (in)
NEO 1	3.3 – 5.6	1.3 – 2.2
NEO 2	4.2 – 7.1	1.6 – 2.8
NEO 3	5.4 – 9.1	2.1 – 3.6
NEO 4	6.9 – 11.7	2.4 – 4.6
NEO 5	8.9 – 15.0	3.5 – 5.9

For ordering information, see "Approved Accessories" in the Appendix.

Position the cuff



NOTE The device and cuffs were validated using the bare upper arm site.



WARNING Patient injury risk. Inaccurate measurement risk. Do not place the cuff where it can disturb proper circulation. Do not place the cuff on any area where circulation is compromised or on any extremity used for intravenous infusions. Do not place the cuff on any limb where intravascular access or therapy, or an arterio-vascular (A-V) shunt is present. Observe the limb concerned to ensure that operation of the device does not result in prolonged impairment of circulation.



CAUTION The blood pressure cuff must be properly positioned to ensure blood pressure accuracy and patient safety. Wrapping the cuff too loosely (preventing proper inflation) may result in inaccurate NIBP readings.



CAUTION If a site other than the bare upper arm is used, the blood pressure measurements may be different. It is important to document the alternate site on the patient record.

Before positioning the cuff, ensure that you have selected the appropriate cuff size.

The device uses the oscillometric method to determine blood pressure; therefore, if the cuff extends to the antecubital fossa (bend in the elbow), you can still acquire an accurate blood pressure reading.

1. Check the cuff for residual air from a previous measurement. Squeeze the cuff as needed to completely deflate the cuff.
2. Position the cuff on the patient's bare upper arm midway between the shoulder and the elbow.
3. Wrap the cuff snugly so that there is room for no more than two fingers between the cuff and the patient's bare upper arm.
4. Position the alignment mark on the cuff directly over the brachial artery.
5. Ensure that the blood pressure tubing has no kinks or twists.



NOTE In situations where you cannot position the cuff level with the heart, you should adjust the measurements as follows for greater accuracy. For each inch (2.54 cm) that the cuff is above the level

of the heart, add 1.8 mmHg to the displayed reading. For each inch (2.54 cm) that the cuff is below the level of the heart, subtract 1.8 mmHg from the displayed reading. It is important to document the adjustment on the patient record.



NOTE For additional guidance address best practices for taking blood pressure measurements, see [Best Practices for Taking Accurate Blood Pressure Readings](#).

Obtain a single NIBP measurement

1. Touch **START** to begin a single measurement.

The **START** button becomes a **STOP** button. NIBP always displays the current inflation rate. When complete, the NIBP parameter displays the completed NIBP measurement.

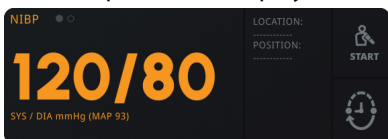

2. Touch **Save** to save the displayed measurement in the patient's record.

The measurement will continue to be displayed until you save it, clear it, or until you start another NIBP measurement.

Interval NIBP measurement

Refer to the "Intervals" section for directions on setting intervals.

The default interval for NIBP measurements is 15 minutes. You can adjust this interval as needed.

Stop automatic measurements



1. On the **Home** tab, touch .
2. Touch **Stop intervals**.

Cancel a NIBP measurement

In the NIBP parameter, touch **STOP**.

The monitor cancels the NIBP measurement and an information message appears informing you that the NIBP reading was stopped and that no reading was captured.

If intervals are turned on, the timer icon counts down to the next automatic measurement and touching stop also turns off the interval.

Temperature







General temperature warnings, cautions, and notes











WARNING Patient injury risk. Always take a temperature measurement with a single-use probe cover securely attached. Failure to use a probe cover can cause patient cross-contamination and inaccurate temperature readings.



WARNING Patient injury risk. Always remain with patient while measuring temperature.

-  **CAUTION** Patient injury risk. Inaccurate measurement risk. Do not use the thermometer if you notice any signs of damage to the probe or the instrument. If the thermometer probe is dropped or damaged, remove it from service and have it inspected by a qualified service person.
-  **CAUTION** Patient injury risk. Do not exceed the recommended temperature measurement durations in Direct mode. Continuous measurement durations of 3 minutes at the oral and rectal sites and 5 minutes at the axillary site are recommended for accurate measurement. Do not continuously measure beyond 10 minutes in any mode.
-  **CAUTION** Inaccurate measurement risk. To ensure optimal accuracy, always confirm that the correct mode and site are selected.
-  **CAUTION** The unit automatically enters Monitor Mode if the probe is withdrawn from the probe well and is not replaced within 60 seconds of inactivity.
-  **CAUTION** Do not use hard or sharp objects to clean the probe well. This could damage the probe well and cause the unit to not function properly.
-  **NOTE** The operator is responsible for checking the compatibility of the monitor, probe, and probe cover before use.

SureTemp Plus warnings, cautions, and notes

-  **WARNING** Patient injury risk. When taking rectal temperatures, insert the probe tip a maximum of 5/8 inch (approximately 1.5 cm) inside the rectum of adults and a maximum of 3/8 inch (approximately 1 cm) inside the rectum of children to avoid the risk of bowel perforation.
-  **WARNING** Patient injury risk. Always take a temperature measurement with a Welch Allyn single-use probe cover securely attached. Failure to use a probe cover can cause patient discomfort from a heated probe, patient cross-contamination, and inaccurate temperature readings.
-  **WARNING** Inaccurate measurement risk. For rectal measurements, apply a thin layer of lubricant to probe cover, if necessary, for patient comfort. Use of excessive lubricant may affect reading accuracy.
-  **CAUTION** Patient injury risk. Do not exceed the recommended temperature measurement durations in Direct mode. Continuous measurement durations of 3 minutes at the oral and rectal sites and 5 minutes at the axillary site are recommended for accurate measurement. Do not continuously measure beyond 10 minutes in any mode.
-  **CAUTION** Patient injury risk. Inaccurate measurement risk. Oral/axillary probes (blue ejection button at top of probe) and blue removable probe wells are used for taking oral and axillary temperatures only. Rectal probes (red ejection button) and red removable probe wells are used for taking rectal temperatures only. Use of the incorrect removable probe well could result in patient cross-contamination. Use of the probe at the wrong site will result in temperature errors.
-  **CAUTION** Inaccurate measurement risk. To ensure optimal accuracy, always confirm that the correct mode and site are selected.
-  **CAUTION** Inaccurate measurement risk. Patient activities such as strenuous exercise, ingesting hot or cold liquids, eating, chewing gum or mints, brushing teeth, or smoking may affect oral temperature measurements for up to 20 minutes.
-  **CAUTION** Never use a damaged temperature probe. The thermometer consists of high-quality precision parts and should be protected from severe impact or shock. Do not use the thermometer if you notice any signs of damage to the probe or monitor. If the thermometer probe is dropped or damaged, remove it from use and have it inspected by qualified service personnel.
-  **CAUTION** Inaccurate measurement risk. Always take an axillary temperature with direct contact between the probe cover and the skin. Carefully place the probe in the axilla, avoiding contact with other objects or material.



CAUTION Probe covers are disposable, nonsterilized, and single-use. Probes are also nonsterilized. Do not autoclave probes and probe covers. Ensure that probe covers are disposed of according to facility requirements or local regulations.

Temperature frame

Located in the lower right corner of the Home tab, the temperature frame contains data and features relevant to temperature measurement.



Temperature measurement display

The frame can display temperature in Celsius and Fahrenheit. Configure the default view in Advanced settings to show °F, °C, or both.

Temperature site selection

Remove the temperature probe and touch the **Temperature site control** to toggle between sites.

Icon	Description
	Pediatric axillary
	Adult axillary
	Oral
	Rectal. Monitors configured with the temperature module and the red rectal probe well and probe default to the rectal mode.

If a rectal probe is used, The rectal icon appears in the temperature brick and the Site Selection feature is not available.

Configure temperature alarms with intervals active

1. Touch the **Alarms** tab.
2. Touch the **Temperature** horizontal tab.
3. Using either the keypad or ▲ or ▼, enter the desired upper and lower alarm limits.

4. Touch the **Home** tab.
The new alarm settings appear in the Alarm Limit control button.

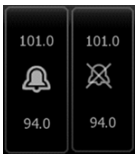
Icon	Button name	Description
	(with Intervals active) Temperature alarm	Displays alarm limits and status with Intervals active. These icons will not appear in Spot monitoring. Touch the button to display the Alarms tab.

SureTemp Plus temperature module

The temperature module uses a thermistor thermometer design and a predictive algorithm to calculate patient temperatures in the Predictive mode.

Temperature mode, Predictive or Direct

The monitor with the temperature module takes a patient temperature in either Predictive (Normal) or Direct mode. The default setting is the Predictive mode.

Direct mode provides continual temperature measurements. For oral and rectal measurements, it is recommended to measure temperature until the temperature stabilizes or for 3 minutes. For axillary measurements, it is recommended to measure temperature until the temperature stabilizes or for 5 minutes. The monitor changes to Direct mode approximately 60 seconds after the probe is removed from the probe well.



NOTE The monitor does not retain Direct mode temperatures in memory unless there is a physiological alarm condition. If there is a physiological temperature alarm condition, the monitor automatically saves the measurement in the patient record. Therefore, it is important to note the temperature before removing the probe from the measurement site and then manually record it in the patient record.

After 10 minutes of using the Direct mode, the monitor stops updating the measurement, generates a technical alarm condition, and clears the measurement.

Take an oral or axillary temperature with the SureTemp Plus thermometer

1. Remove the temperature probe from the probe well.
The monitor sounds a tone as it enters the ready state.
2. Insert the probe into a new probe cover and press the probe handle down firmly.
3. Touch **Temperature site control** to select the measurement site: oral, pediatric axillary, or adult axillary.
4. Hold the probe tip in place at the measurement site.

While the measurement is being obtained, the temperature frame displays the process indicator.

The monitor sounds a tone when the final temperature is obtained (in approximately 6 to 15 seconds). The temperature frame displays the temperature in degrees Fahrenheit, degrees Celsius, or both depending on your facility's configuration.



NOTE The monitor does not retain Direct mode temperatures in memory unless there is a physiological alarm condition. If there is a physiological temperature alarm condition, the monitor automatically saves the measurement in the patient record. Therefore, it is important to note the temperature before removing the probe from the measurement site and then manually record it in the patient record.

5. Remove the probe after the temperature measurement is obtained and firmly press the eject button on the top of the probe to release the probe cover.

- Return the probe to the probe well.

Take a rectal temperature with the **SureTemp Plus** thermometer



WARNING Patient injury risk. When taking rectal temperatures, insert the probe tip only 5/8 inch (approximately 1.5 cm) inside the rectum of adults and only 3/8 inch (approximately 1 cm) inside the rectum of children to avoid the risk of bowel perforation.



WARNING Cross-contamination or nosocomial infection risk. Thorough hand-washing greatly reduces the risk of cross-contamination and nosocomial infection.



WARNING Patient injury risk. Do not exceed the recommended temperature measurement durations in Direct mode. Continuous measurement durations of 3 minutes at the oral and rectal sites and 5 minutes at the axillary site are recommended for accurate measurement. Do not continuously measure beyond 10 minutes in any mode.



WARNING Inaccurate measurement risk. To ensure optimal accuracy, always confirm that the correct mode and site are selected.



CAUTION Probe covers are disposable, nonsterilized, and single-use. Probes are also nonsterilized. Do not autoclave probes and probe covers. Ensure that probe covers are disposed of according to facility requirements or local regulations.

- Remove the rectal temperature probe from the rectal probe well.
The monitor sounds a tone as it enters the ready state. The Temperature Site Control defaults to the rectal site.
- Insert the rectal probe into a new probe cover and press the probe handle down firmly.
- Perform a rectal temperature measurement using medical best practices. While the measurement is taking place, the temperature frame displays the process indicator.
- The monitor sounds a tone when the final temperature is reached (in approximately 10 to 13 seconds). The temperature frame continues to display the temperature in degrees Fahrenheit and degrees Celsius even after the probe is returned to the probe well.



NOTE The monitor does not retain Direct mode temperatures in memory unless there is a physiological alarm condition. If there is a physiological temperature alarm condition, the monitor automatically saves the measurement in the patient record. Therefore, it is important to note the temperature before removing the probe from the measurement site and then manually record it in the patient record.

- Remove the probe after the temperature measurement is complete and firmly press the eject button on the top of the probe to release the probe cover.
- Return the probe to the probe well.

SpO₂

SpO₂ monitoring

SpO₂ and pulse rate monitoring continuously measures functional oxygen saturation of arteriolar hemoglobin as well as the pulse rate in a patient through a pulse oximeter. SpO₂ measurements are updated each 1 ± 0.5 seconds.

The SpO₂ sensors provided by Masimo and Nellcor for use with the monitor have been tested for biocompatibility in accordance with ISO 10993.

SpO₂ alarms

The monitor can capture SpO₂ measurements based on the intervals you choose on the Settings tab.



NOTE If configured for the optional Respiration Rate, the monitor also measures respiratory rate through photoplethysmogram analysis of SpO2 (**RRp**).

Select response mode

1. Touch the **Settings** tab.
2. Touch the **Parameters** tab.
3. In the SpO2 section, touch the toggle button to select **Normal** or **Fast** response mode.

Configure SpO2 alarms with intervals active

1. Touch the **Alarms** tab.
2. Touch the **SpO2** horizontal tab.
3. Ensure that the SpO2 alarm limit control is set to ON.



NOTE If any parameter's alarm limit control is set to OFF, you cannot adjust alarm limits on the Alarm tab, and no visual or audio signals will occur for that specific parameter.

4. Using the  (keypad) or ▲ or ▼, enter the desired upper and lower alarms limits.
5. Touch the **Home** tab.

The new alarm settings appear in the alarm limit control button.

SpO2 alarm delay

Alarm delays are configurable using a configuration file. See "Welch Allyn Product Configuration Tool" section for more information.

- If the monitor is configured with Masimo SpO2 sensor the delay can be configured to 0, 10, 15 or 30 seconds with default delay as 10 seconds.
- If the monitor is configured with Nellcor SpO2 sensor the delay can be configured to 0, 10, 15, 30 seconds or **SatSeconds**. See "**SatSeconds** alarm management" section for more information on **SatSeconds**.



NOTE Visual and audio cues will be delayed per user selection.

SpO2 frame

The SpO2 frame displays data and the controls used in pulse oximetry measurements.

The frame provides a numeric view and a waveform view of SpO2 data. You can toggle between views by touching the left side of the frame.



The SpO2 frame remains blank if no SpO2 measurement has been acquired.

SpO2 numeric view

The numeric view indicates the SpO2 saturation percentage and the pulse amplitude.

The SpO2 saturation percentage ranges between zero and 100. The SpO2 reading is updated each 1 ± 0.5 seconds.

Pulse amplitude

The pulse amplitude bar indicates the pulse beat and shows the relative pulse strength. More bars illuminate as the detected pulse gets stronger.

Level of perfusion (Masimo only)

Masimo displays the LofP as a numeric value and refers to it as Perfusion Index.

The level of perfusion (LofP) is a relative reading of pulse strength at the monitoring site. The LofP is a numerical value that indicates the strength of the infrared (IR) signal returning from the monitoring site. The LofP display ranges from .02 percent (very weak pulse strength) to 20 percent (very strong pulse strength). The LofP is a relative number and varies between monitoring sites and from patient to patient, as physiological conditions vary.

During sensor placement, the LofP can be used to evaluate the appropriateness of an application site by looking for the site with the highest LofP number. Placing the sensor at the site with the strongest pulse amplitude (the highest LofP number) improves performance during motion. Monitor the trend of the LofP for changes in physiological conditions.

SatSeconds alarm management

The **SatSeconds** feature is an SpO₂ alarm management system available only with monitors that are equipped with Nellcor SpO₂ **OxiMax** Technology.

The **SatSeconds** feature is the product of the time and magnitude that a patient falls outside of the SpO₂ alarm limits. For example, three points below the alarm limit for 10 seconds equals 30 **SatSeconds**. An alarm is triggered only when a desaturation event reaches the **SatSeconds** limit.

With the online configuration tool, authorized personnel can select and configure the **SatSeconds** feature. The **SatSeconds** feature can be set to 0, 10, 25, 50, or 100 **SatSeconds** using the configuration tool. If a desaturation event resolves on its own within the preset time, the clock will automatically reset and the monitor will not alarm.



NOTE The **SatSeconds** feature has a built-in safety protocol that sounds an alarm whenever three SpO₂ violations of any amount or duration occur within a 1-minute period.

Measure SpO₂ and pulse rate

When SpO₂ alarms are turned off, intervals are running, and the SpO₂ value in the SpO₂ frame has not updated within 30 seconds, the SpO₂ value in the frame is replaced with ??.

The SpO₂ sensor measures oxygen saturation and pulse rate. For a monitor equipped with a Masimo SpO₂ sensor, the SpO₂ sensor optionally measures respiration rate. (Optional, see the Service manual for upgrade options available.) Oxygen saturation is displayed as a percentage from zero (0) to 100%. The oxygen saturation and pulse rate are updated and refreshed each 1 ± 0.5 seconds.

The warnings and cautions listed below apply to Masimo and Nellcor SpO₂ sensors.



WARNING Inaccurate measurement risk. Use only Masimo sensors and accessories on Masimo-equipped monitors.















WARNING Inaccurate measurement risk. Use only Nellcor sensors and accessories on Nellcor-equipped monitors.



WARNING Inaccurate measurement risk. Severe anemia may cause erroneous SpO₂ readings.



WARNING Inaccurate measurement risk. The pulse oximeter can be used during defibrillation, but the readings may be inaccurate for up to 20 seconds.

-  **WARNING** Inaccurate measurement risk. Venous congestion may cause under reading of actual arterial oxygen saturation. Therefore, assure proper venous outflow from monitored site. Sensor should not be below heart level (e.g. sensor on hand of a patient in a bed with arm dangling to the floor).
-  **WARNING** The pulsations from intra-aortic balloon support can increase the pulse rate displayed on the monitor. Verify the patient's pulse rate against the ECG heart rate.
-  **WARNING** Patient injury risk. Do not attempt to reprocess, recondition, or recycle any sensors or patient cables. Doing so might damage electrical components.
-  **WARNING** Patient injury risk. The **Pulse CO-Oximeter** is not an apnea monitor.
-  **WARNING** Patient injury risk. To avoid cross contamination only use Masimo single use sensors on the same patient.
-  **WARNING** Unless otherwise specified, do not sterilize sensors or patient cables by irradiation, steam, autoclave or ethylene oxide. See the cleaning instructions in the Instructions for use for the Masimo re-useable sensors.
-  **WARNING** Patient injury risk. Loss of pulse signal can occur when the patient has severe anemia or hypothermia.
-  **WARNING** SpO₂ is empirically calibrated in healthy adult volunteers with normal levels of carboxyhemoglobin (COHb) and methemoglobin (MetHb).
-  **WARNING** Do not use NIBP or other constricting instruments on the same appendage as the sensor.
-  **WARNING** High-intensity extreme lights, such as pulsating strobe lights, directed on the sensor may not allow the pulse oximeter to obtain vital sign readings.
-  **WARNING** Pulse rate measurement might not detect certain arrhythmias because it is based on the optical detection of a peripheral flow pulse. Do not use the pulse oximeter as a replacement or substitute for ECG-based arrhythmia analysis.
-  **WARNING** Use the pulse oximeter as an early warning device. As you observe a trend toward patient hypoxemia, use laboratory instruments to analyze blood samples to better understand the patient's condition.
-  **WARNING** The accuracy of SpO₂ measurements can be affected by any of the following:
- elevated levels of total bilirubin
 - elevated levels of Methemoglobin (MetHb)
 - elevated levels of Carboxyhemoglobin (COHb)
 - hemoglobin synthesis disorders
 - low perfusion at the monitored site
 - the presence of concentrations of some intravascular dyes, sufficient to change the patient's usual arterial pigmentation
 - patient movement
 - patient conditions such as shivering and smoke inhalation
 - motion artifact
 - painted nails
 - poor oxygen perfusion
 - hypotension or hypertension
 - severe vasoconstriction
 - shock or cardiac arrest
 - venous pulsations or sudden and significant changes in pulse rate
 - proximity to an MRI environment

- moisture in the sensor
- excessive ambient light, especially fluorescent
- the use of the wrong sensor
- a sensor applied too tightly



WARNING High oxygen concentrations may predispose a premature infant to retinopathy. Therefore, the upper alarm limit for the oxygen saturation must be carefully selected in accordance with accepted clinical standards.



WARNING Patient injury risk. Incorrect sensor application or excessive duration of sensor use can cause tissue damage. Inspect the sensor site periodically as directed in the sensor manufacturer's instructions.



CAUTION If using pulse oximetry during full body irradiation, keep the sensor out of the irradiation field. If the sensor is exposed to the irradiation, the reading might be inaccurate or the unit might read zero for the duration of the active irradiation period.



CAUTION The instrument must be configured to match your local power line frequency to allow for the cancellation of noise introduced by fluorescent lights and other sources.



CAUTION Exercise caution when applying a sensor to a site with compromised skin integrity. Applying tape or pressure to such a site may reduce circulation and/or cause further skin deterioration.



CAUTION If the Low Perfusion message is frequently displayed, find a better perfused monitoring site. In the interim, assess the patient and, if indicated, verify oxygenation status through other means.



CAUTION Do not modify or alter the sensor in any way. Alterations or modification may affect performance and/or accuracy.

1. Verify that the sensor cable is connected to the monitor.
2. Clean the application site. Remove anything, such as nail polish, that could interfere with sensor operation.



NOTE Do not use disposable sensors on patients who have allergic reactions to the adhesive.

3. Attach the sensor to the patient according to the manufacturer's instructions for use, observing all warnings and cautions.



NOTE If a sterile sensor is required, select a sensor that has been validated for sterilization, and follow the sensor manufacturer's instructions for sterilizing the sensor.

Place the sensor and the NIBP cuff on different limbs to reduce unnecessary alarms when you monitor these parameters at the same time.



NOTE Consult the sensor manufacturer's instructions for selecting the correct sensor.

4. Confirm that the monitor displays SpO₂ and pulse rate data within 10 seconds or less after connecting the sensor to the patient. If excessive patient movement is observed or signal quality is low, check that the sensor is properly and securely applied. If the issue persists, move the sensor to a less active location. Alternately, use an adhesive sensor to improve skin contact or use a new sensor with fresh adhesive backing.

While SpO₂ is being measured, the displayed pulse rate is acquired from the sensor. If SpO₂ is not available, the pulse rate is acquired from NIBP. The monitor identifies SpO₂ or NIBP as the pulse rate source.

An alarm sounds if you detach the sensor during a measurement in intervals mode.

If SpO₂ is being measured continuously on a patient for an extended period, change the sensor location at least every three hours or as indicated by the sensor manufacturer's instructions.

Pulse rate frame

The pulse rate frame is located in the upper right of the Home tab. The pulse rate frame displays data, information, and the controls used in reading pulse rates.

Typically, the pulse rate is derived from the SpO2 sensor. If SpO2 is not available, the pulse rate is derived from NIBP or manually obtained.

The source of the pulse rate is displayed beneath the numeric representation of the pulse rate.



WARNING Inaccurate measurement risk. Pulse rate measurements generated through the blood pressure cuff or through SpO2 are subject to artifact and might not be as accurate as heart rate measurements generated through ECG or manual palpation.

Configure pulse rate alarms with intervals active

1. Touch the **Alarms** tab.
2. Touch the **Pulse rate** horizontal tab.
3. Using either the keypad or ▲ or ▼, enter the desired upper and lower alarm limits.
4. Touch the **Home** tab.

The new alarm settings appear in the pulse rate alarm limit control button.

RRp measurement [Respiration Rate]

When configured at purchase or via service upgrade, the monitor measures respiratory rate through photoplethysmogram analysis of SpO2. This process is known as **RRp** from Masimo. The proper configuration includes the monitor equipped with Masimo **SET** pulse oximetry technology with **RRp** monitoring enabled, and a Masimo sensor. When properly equipped, the monitor analyzes changes in the plethysmographic waveform. (See the *Service manual* for upgrade options available.)

Respiration rate alarms

Respiration rate alarm limits

Manual respiration rate and measured respiration rate limits for adult and pediatric patient types:

- For adults, the lower range of the alarm limit is 5 to 67 BPM.
- For adults, the upper range of the alarm limit is 7 to 69 BPM.
- For pediatrics, the lower range of the alarm limit is 5 to 67 BPM.
- For pediatrics, the upper range of the alarm limit is 7 to 69 BPM.

Manual respiration rate alarm limits

- For neonates, the lower range of the alarm limit is 1 to 96 BPM.
- For neonates, the upper range of the alarm limit is 3 to 98 BPM.

Respiration rate alarm delay

Alarm delays are configurable using a configuration file. See "Welch Allyn Product Configuration Tool" section for more information.

If the monitor is configured with Masimo SpO2 sensor the delay can be configured to 0, 10, 15 or 30 seconds with default delay as 10 seconds.

Configure respiration rate alarms with intervals active

1. Touch the **Alarms** tab.
2. Touch the **Respiration rate** horizontal tab.
3. Using the keypad or ▲ or ▼, enter the desired upper and lower alarms limits.
4. Touch the **Home** tab.

The new alarm settings appear in the Alarm Limit control button.

Respiration rate measurements [Using Masimo SpO2]

The Masimo SpO2 module for use with the monitor has been tested for biocompatibility in accordance with ISO 10993.



WARNING Patient injury risk. Do not start or operate the **Pulse CO-Oximeter** unless the setup was verified to be correct.



WARNING Do not use the **Pulse CO-Oximeter** if it appears or is suspected to be damaged.



WARNING Patient injury risk. If any measurement seems questionable, first check the patient's vital signs by alternate means and then check the **Pulse CO-Oximeter** for proper functioning.



WARNING Inaccurate measurement risk. Inaccurate respiration rate measurements may be caused by the following:

- Improper sensor application
- Low arterial perfusion
- Motion artifact
- Low arterial oxygen saturation
- Excessive ambient or environmental electrical noise



WARNING Inaccurate measurement risk. Inaccurate SpO2 readings may be caused by the following:

- Improper sensor application and placement
- Elevated levels of COHb or MetHb: High levels of COHb or MetHb may occur with a seemingly normal SpO2. When elevated levels of COHb or MetHb are suspected, laboratory analysis (CO-Oximetry) of a blood sample should be performed.
- Elevated levels of bilirubin
- Elevated levels of dyshemoglobin
- Vasospastic disease, such as Raynaud's, and peripheral vascular disease
- Hemoglobinopathies and synthesis disorders such as thalassemias, Hb s, Hb c, sickle cell, etc.
- Hypocapnic or hypercapnic conditions
- Severe anemia
- Very low arterial perfusion
- Extreme motion artifact
- Abnormal venous pulsation or venous constriction
- Severe vasoconstriction or hypothermia
- Arterial catheters and intra-aortic balloon
- Intravascular dyes, such as indocyanine green or methylene blue
- Externally applied coloring and texture, such as nail polish, acrylic nails, glitter, etc.
- Birthmark(s), tattoos, skin discolorations, moisture on skin, deformed or abnormal fingers. etc.
- Skin color disorders



WARNING Interfering Substances: Dyes or any substance containing dyes that change usual blood pigmentation may cause erroneous readings.



WARNING The **Pulse CO-Oximeter** should not be used as the sole basis for diagnosis or therapy decisions. It must be used in conjunction with clinical signs and symptoms.



WARNING The **Pulse CO-Oximeter** is not intended to be used as the sole basis for making diagnosis or treatment decisions related to suspected carbon monoxide poisoning; it is intended to be used in conjunction with additional methods of assessing clinical signs and symptoms.



WARNING Patient injury risk. The **Pulse CO-Oximeter** is not an apnea monitor.



WARNING The **Pulse CO-Oximeter** may be used during defibrillation, but this may affect the accuracy or availability of the parameters and measurements.



WARNING The **Pulse CO-Oximeter** may be used during electrocautery, but this may affect the accuracy or availability of the parameters and measurements.



WARNING The **Pulse CO-Oximeter** should not be used for arrhythmia analysis.



WARNING SpO2 is empirically calibrated in healthy adult volunteers with normal levels of carboxyhemoglobin (COHb) and methemoglobin (MetHb).



WARNING Do not adjust, repair, open, disassemble, or modify the **Pulse CO-Oximeter** or accessories. Injury to personnel or equipment damage could occur. Return the **Pulse CO-Oximeter** for servicing if necessary.



WARNING Optical, pleth-based measurements, such as SpO2 and **RRp** measurement, can be affected by the following:

- Improper sensor application or use of incorrect sensor.
- Blood pressure cuff applied to the same arm as the sensor site.
- Intravascular dyes such as indocyanine green or methylene blue.
- Venous congestion.
- Abnormal venous pulsations (e.g. tricuspid valve regurgitation, Trendelenburg position).
- Abnormal pulse rhythms due to physiological conditions or induced through external factors (e.g. cardiac arrhythmias, intra-aortic balloon, etc.).
- Externally applied coloring and texture such as nail polish, acrylic nails, glitter, etc.
- Moisture, birthmarks, skin discoloration, nail aberration, deformed fingers, or foreign objects in the light path.
- Elevated levels of bilirubin.
- Physiological conditions that can significantly shift the oxygen disassociation curve.
- A physiological condition that may affect vasomotor tone or changes in vasomotor tone.



NOTE Physiological conditions that result in loss of pulsatile signal may result in no SpO2 or **RRp** measurement readings.

Respiration Rate [RR] frame



NOTE The frame displays respiration rate measurements. The RESPIRATION RATE frame displays data from the pulse oximetry option.



NOTE Physiological conditions that result in loss of pulsatile signal may result in no SpO2 or **RRp** measurement readings.

The RESPIRATION RATE numeric view indicates the breaths per minute (BPM). The source of the respiration rate is displayed beneath the numeric representation of the respiration rate and the breaths per minute (BPM).

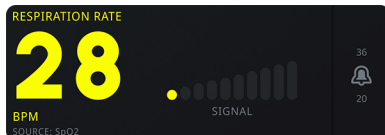

The RESPIRATION RATE signal strength with fewer bars indicates a low signal strength and a higher number of bars indicates a higher strength.



NOTE The Respiration rate only applies to a monitor equipped with a Masimo SpO2 sensor and the respiration rate option.

The last respiration rate measurement remains on the screen unless you touch **Save** or **Clear**, or until a new measurement is taken. The RESPIRATION RATE frame remains blank if no respiration rate measurement has been acquired. Respiration rate measurements are only available for adult and pediatric patient types.

Maintenance and service

Perform periodic checks

1. Verify the following at least daily:
 - The audio speaker tone, especially at startup
 - The touchscreen alignment
 - The date
 - The time
2. Visually inspect the following at least weekly:
 - The monitor for any damage or contamination
 - All cables, cords, and connector ends for damage or contamination
 - All mechanical parts, including covers, for integrity
 - All safety-related labeling for legibility and adhesion to the monitor
 - All accessories (cuffs, tubing, probes, sensors) for wear or damage
 - Documentation for current revision of the monitor
3. Visually inspect the following at least monthly:
 - The mobile stand wheels for wear and faulty operation
 - The mounting screws on wall units or carts for looseness and wear

Inspection

Routinely inspect the **Connex 360** monitor and accessories for wear, fraying, or other damage. Do not use if you see signs of damage, if the monitor malfunctions, appears not to be working properly, or if you notice a change in performance. Contact Baxter Technical Support: [Technical Support](#) for assistance.



NOTE Battery Care - When the device is stored for an extended period, the battery must be maintained to prevent deep discharge, which will shorten the life of the battery. Prior to storage, charge the battery to 100%. Every 30 days, remove the device from storage and recharge the battery.

Replace the monitor battery



WARNING Personal injury risk. Improper handling of the battery can lead to heat generation, smoke, explosion or fire. Do not short-circuit, crush, incinerate, disassemble the battery, or use an unapproved battery pack. Never dispose of batteries in refuse containers. Always recycle batteries according to national or local regulations.



WARNING Use only approved accessories, and use them according to the manufacturer's instructions for use. Using unapproved accessories with the monitor can affect patient and operator safety and can compromise product performance and accuracy, and void the product warranty.

1. Locate the battery cover, indicated by .

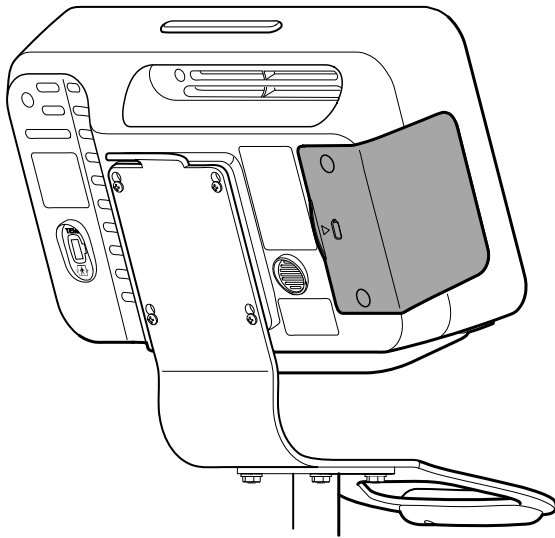

2. Using a double-slotted screwdriver, loosen the captive screws of the battery cover, and then remove the cover.
3. Remove the old battery from the battery compartment.

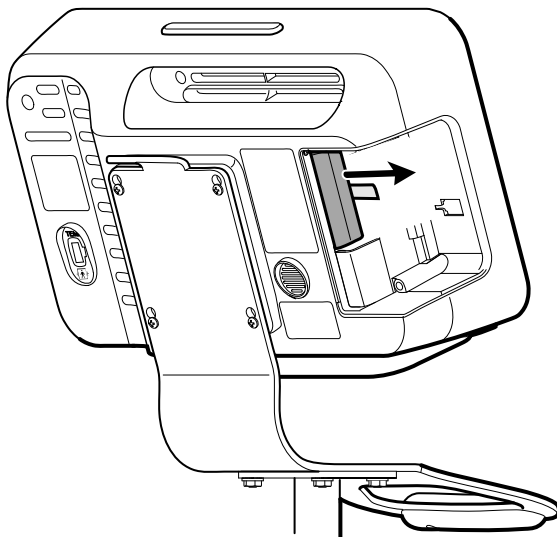

4. Insert the new battery into the battery compartment.



NOTE Do not remove the tab label from the battery. This tab helps you remove the battery from the compartment when you need to replace it.

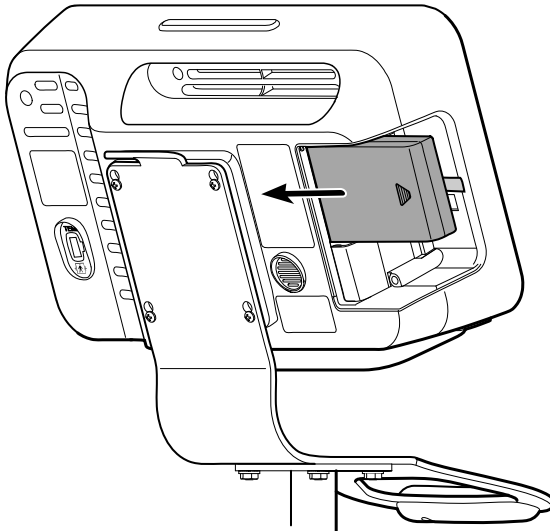

5. Replace the battery cover, and then tighten the captive screws of the battery cover.



NOTE Do not overtighten the screws.

Clean and disinfect the equipment

This section presents procedures for cleaning and disinfecting the device (including the device, stand, accessories, and accessory basket and bins).

Cleaning refers to the removal of dirt, germs (microorganisms), and impurities from surfaces. Cleaning does not kill germs, but by removing many of them and lowering their numbers, it reduces the risk of spreading infection.

Disinfecting is the process of cleaning a surface to eliminate pathogenic microorganisms, such as bacteria, viruses, and fungi, to a level that is considered safe according to public health standards. This is typically achieved using chemical agents known as disinfectants, which are specifically designed to kill harmful microorganisms. Disinfecting is distinct from cleaning, which involves removing dirt and debris, and some germs, and it is different from sterilizing, which involves killing all forms of microbial life.

Baxter has validated these instructions to be capable of preparing your device and above accessories for re-use. Clean and disinfect on a routine basis according to your facility's protocols and standards or local regulations.



WARNING Patient injury risk. Clean all accessories, including cables and tubes, before storing the accessories on the device or stand. This helps reduce the risk of cross contamination and nosocomial infection.



WARNING Electric shock hazard. Before cleaning and disinfecting the monitor, disconnect the AC power cord from the mains outlet and the power source.



WARNING Electric shock hazard. DO NOT immerse or autoclave the monitor or accessories. The monitor and the accessories are not heat-resistant.



WARNING Electric shock hazard. DO NOT open the monitor or attempt repairs. The monitor has no user-serviceable internal parts. Only perform routine cleaning and maintenance procedures specifically described in this manual. Inspection and servicing of internal parts shall only be performed by qualified service personnel.

 **CAUTION** Liquids can damage electronics inside the device and accessories. Prevent liquids from spilling on the device.

 **CAUTION** Clean and disinfect all accessories, including cables and hoses, before storing the accessories on the device or stand. This helps reduce the risk of cross contamination and nosocomial infection.

Power down the monitor

1. Press .

If there is no system message, a dialog box appears with options.

- Sign out (if you signed in with a Clinician ID)
- Power down
- Sleep
- Cancel

2. Touch **Power down**.



Disconnect AC power

 **CAUTION** Never move the monitor or mobile stand by pulling on any of the cords. This may cause the monitor to tip over or damage the cord. Never pull on the power cord when disconnecting the cord from the mains outlet. When disconnecting the power cord, always grasp by the attachment plug. Keep the cord away from liquids, heat, and sharp edges. Replace the power cord if the strain relief, cord insulation, or metal prongs are damaged or begin to separate from the attachment plug.

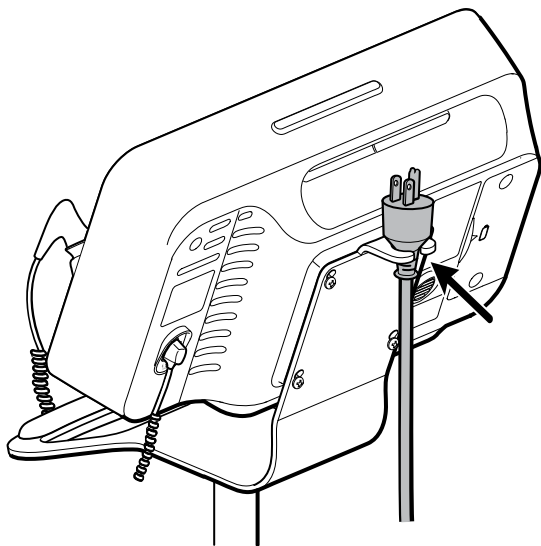
1. Grasp the power cord by the attachment plug.
2. Pull the power cord attachment plug out from the mains outlet.
3. When not in use, set the power cord attachment plug into the catch on the top of the mobile stand support bracket to keep the power cord clear of the wheels and to minimize trip hazards.



Prepare the device for cleaning and disinfection

1. Unplug the device from the electrical mains outlet.  

2. Use as many disinfecting wipes as necessary to ensure the wipe remains wet, but not dripping during both the cleaning and disinfection steps.
3. Follow the directions on the disinfecting wipes manufacturing label.
4. For cleaning the VESA mount, use only 70 percent isopropyl alcohol solution applied to a clean cloth.
5. Clean and disinfect the scanner according to manufacturer's directions.
6. Do not clean or disinfect the disposable blood pressure cuff. Replace it if soiled. Follow the manufacturer's instructions for reusable cuffs and tubing.
7. Remove the oximetry sensor and cable for separate cleaning and disinfecting instructions according to the manufacturer's directions.
8. Clean and disinfect thermometer probe and cable according to the **SureTemp** thermometer instructions, which can be found at [SureTemp Instructions](#).

Step 1: Cleaning

1. Remove the wipe from the disinfecting wipes container.
2. Wipe all surfaces of the device, including the top, sides, front, rear, and bottom of the device. Use as many wipes as needed to wipe all surfaces.
3. Wipe cords and stand.
4. Discard any used wipe(s).
5. Wash your hands thoroughly.

Step 2: Disinfection

1. Use a new disinfecting wipe, wipe down all surfaces of the device, including the top, sides, front, rear, and bottom of the device.
2. Use enough wipes for all treated surfaces to remain visibly wet per the disinfectant manufacturer's instructions for use. Reapply disinfectant as needed to keep the area visibly wet.
3. Wipe cords and stand. Make sure all wiped surfaces remain visibly wet per the disinfectant manufacturer's instructions for use.
4. Discard any used wipe(s).
5. Wash your hands thoroughly.

Approved cleaning and disinfecting agents

Section 1. Approved cleaning agents for **Connex 360** monitor surface



NOTE Follow the "Step 1: Cleaning" instructions using a cleaning agent from the following table. If one of the following cleaning agents come as a solution rather than as a wipe, apply to a clean cloth.

Cleaning agent
CaviWipes
Clinell Universal Wipes
Sani-Cloth Plus
Super Sani-Cloth
70 percent isopropyl alcohol solution
BacilloI AF Wipes

Cleaning agent
CleanCide
Clorox Healthcare Fuzion
Clorox Dispatch
Clorox Healthcare Bleach Germicidal Cleaner
Mikrozyd AF Wipes
Oxivir TB
Oxivir 1 Wipes
Oxivir Plus 1:40 Solution
Reynard Neutral Detergent Wipes
Reynard Premier Detergent Wipes
Sani-Cloth Bleach
Sani-Cloth Prime Wipes
Tuffie5 Cleaning Wipes
Virex II (256)
Bleach solution (5% - 8.25% Sodium Hypochlorite diluted according to the manufacturer's instructions ¹)
¹ Up to 2,400 parts per million (ppm) available chlorine

Section 2. Approved disinfecting agents for **Connex 360** monitor components



NOTE The following disinfecting agents are approved for low level disinfection of the **Connex 360** components.

1. Follow the "Step 2: Disinfection" instructions using a disinfecting agent from the following table. If one of the following disinfecting agents comes as a solution rather than as a wipe, apply to a clean cloth.

Disinfecting agent	Dwell time
Clinell Universal Wipes	As specified by the manufacturer
70% isopropyl alcohol solution	2 minutes
Super Sani-Cloth	As specified by the manufacturer

When cleaning residue is present on the display, clean with a 5-8% acetic acid solution.



CAUTION Some cleaning and disinfecting agents are not appropriate for all components of the device and accessories. Use only approved cleaning and disinfecting agents, and observe any restrictions noted for some components in the tables. Using unapproved cleaning and disinfecting agents may cause damage to components.



CAUTION Do not spray any cleaning or disinfecting agent solution directly onto the monitor. Excess solution entering the monitor assembly could damage internal components. Also use caution to ensure that any cleaning or disinfecting cloth is not saturated with solution.



CAUTION Do not use bleach solutions of any kind when cleaning metal electrical contacts. They will damage the device and accessories.

Remove liquid spills from the monitor

Liquids can damage electronics inside the monitor. Follow these steps if liquids spill on the monitor.

1. Power down the monitor.
2. Disconnect the power cord from the mains outlet and the power source.
3. Remove battery pack from the monitor.
4. Dry excess liquid from the monitor.
5. Reinstall battery pack.
6. Reconnect the power cord.
7. Power on the monitor and verify that the monitor functions normally before using it.

If liquids possibly entered the monitor, remove the monitor from use until it has been properly dried, inspected, and tested by qualified service personnel.

Store the device

Store the device according to facility guidelines to keep the device clean, dry, and ready for service.

Device disposal

Disposal of the device must be in accordance with the following steps:

1. Follow cleaning instructions per instructions in this user manual section.
2. Delete all existing data related to patients/hospital/clinic/clinicians.
3. For security purposes, take a hammer, or other suitable tool, and destroy all the micro-controller chips on the Printed Circuit Board Assembly (PCBA) of the device before recycling the device.
See the Service manual for further details about disassembling the device and removing the PCBA.
4. Segregate material in preparation for the recycling process
 - Components are to be disassembled and recycled based on type of material
 - Plastic to be recycled as plastic waste
 - Metal to be recycled as metal
 - Includes loose components containing more than 90% metal by weight
 - Includes screws and fasteners
 - Electronic components, including the power cord, to be disassembled and recycled as Waste of Electrical and Electronic Equipment (WEEE)
 - Batteries to be dismantled from the device and recycled as per WEEE

Users must adhere to all federal, state, regional, and/or local laws and regulations as they pertain to the safe disposal of medical devices and accessories. If in doubt, the user of the device should first contact Baxter Technical Support: [Technical Support](#) for guidance on safe disposal protocols.

For more specific disposal or compliance information, follow the Baxter link for WEEE recycling information: [WEEE recycling information](#).

Technical alarm and information messages

This section presents tables of technical alarm and information messages, as well as problem descriptions that do not generate messages, to help you troubleshoot issues on the monitor.



NOTE Problem descriptions without messages appear at the end of this section.

When the monitor detects certain events, a message appears in the Device Status area at the top of the screen. Below are the message types.

- Information messages, which appear on a blue background.
- Very low-priority alarms, which appear on a cyan background.
- Low- and medium-priority alarms, which appear on an amber background.
- High-priority alarms, which appear on a red background.

Technical alarm messages are low or very low priority unless noted in the Message column.

Alarm logs are not viewable by clinicians. In the event of an unplanned power failure, all information, including device logs and patient data, are retained on the system.

You can dismiss a message by touching the message on the screen or, for some messages, you can wait for the message to time out.

To use these tables, locate the message that displays on the monitor in the left column of the table. The remainder of the row explains possible causes and suggests actions that can resolve the issue.



NOTE Instructions to "Call for service" in the following tables mean that you should contact qualified service personnel in your facility to investigate the issue.

NIBP messages

Condition	Cause	Remedy	Priority
Alarm limit exceeded. NIBP diastolic High. 050049	Diastolic pressure exceeded the rated measurement range	N/A	High
Alarm limit exceeded. NIBP diastolic Low. 05004A	Diastolic pressure is below the rated measurement range	N/A	High
Alarm limit exceeded. NIBP MAP High. 05004B	MAP pressure exceeded the rated measurement range	N/A	High
Alarm limit exceeded. NIBP MAP Low. 05004C	MAP pressure is below the rated measurement range	N/A	High
Alarm limit exceeded. NIBP systolic High. 050047	Systolic pressure exceeded the rated measurement range	N/A	High

Technical alarm and information messages

Condition	Cause	Remedy	Priority
Alarm limit exceeded. NIBP systolic Low. 050048	Systolic pressure is below the rated measurement range	N/A	High
User canceled NIBP reading.	The NIBP measurement was canceled by user	Clear the alarm and retry NIBP.	Information
NIBP not functional. 050002	The NIBP measurement is not available	Internal malfunction. If the problem persists, replace the module.	Medium
Unable to determine NIBP; check connections; limit patient movement. 050003	The NIBP measurement may be inaccurate, patient motion occurred, or the settings for patient readings obtained might not be accurate	Make sure the NIBP settings/patient mode is appropriate. If the problem persists, replace the module.	Medium
Unable to determine NIBP; check connections; limit patient movement. 050004	Excessive artifact, no blood pressure parameters could be calculated	Unable to determine blood pressure. Check connections; restrict patient movement. If problem persists, replace module.	Low
Unable to determine NIBP; check inflation settings. 050005	Low inflation on blood pressure measurement attempt	Make sure the NIBP settings/patient mode is appropriate. If the problem persists, replace the module.	Low
Unable to determine NIBP; check connections and tubing for kinks. 050006	The NIBP tubing has a kink, or there is a NIBP transducer calibration failure	Internal malfunction. If the problem persists, replace the module.	Medium
Unable to determine NIBP; check connections; limit patient movement. 050007	The blood pressure measurement dumped too soon	Make sure the NIBP settings/patient mode is appropriate. If the problem persists, replace the module.	Low
Unable to determine NIBP; check connections; limit patient movement. 050008	There were not enough steps on the measurement attempt	Unable to determine blood pressure. Check connections; restrict patient movement.	Low
Unable to determine NIBP; check inflation settings. 050009	There is invalid patient information for the selected mode	Make sure the NIBP settings/patient mode is appropriate. If the problem persists, replace the module.	Medium
Unable to determine NIBP; check connections; limit patient movement. 05000A	The re-inflation was too late on the measurement attempt	Unable to determine blood pressure. Check connections; restrict patient movement.	Low

Condition	Cause	Remedy	Priority
Unable to determine NIBP; check inflation settings. 05000B	There were many re-inflate attempts on the measurement attempt	Unable to determine blood pressure. Check connections; restrict patient movement.	Low
Unable to determine NIBP; check connections and tubing for kinks. 05000C	Couldn't bleed pressure below safe venous return pressure	Unable to release cuff pressure. Check tubing for kinks and connection integrity.	Medium
NIBP air leak; check cuff and tubing connections. 05000D	Leak was detected in BP cycle.	Check the tubing and connections.	Low
No display	The safety check failed on the measurement attempt	Internal malfunction. If the problem persists, replace the module.	
Unable to determine NIBP; check connections; limit patient movement. 05000F	Auto Zero check failure. The NIBP pressure is not stable and the transducer zero value cannot be set	The NIBP pressure is not stable and the transducer zero value cannot be set. If problem persists, replace module.	Medium
NIBP not functional. 050105	WACP message CRC mismatch on NIBP module	Internal malfunction. If the problem persists, replace the module.	Very low
NIBP not functional. 050201	This message is not implemented by the NIBP module	Internal malfunction. If the problem persists, replace the module.	Very low
NIBP not functional. 050202	This message is not supported by the NIBP module	Internal malfunction. If the problem persists, replace the module.	Very low
NIBP not functional. 050203	The NIBP module has run out of memory	Internal malfunction. If the problem persists, replace the module.	Very low
NIBP not functional. 050205	The NIBP module has received a invalid parameter	Internal malfunction. If the problem persists, replace the module.	Very low
NIBP not functional. 050206	The parameter provided by the NIBP module is outside of the allowable range for the specified message	Internal malfunction. If the problem persists, replace the module.	Very low
NIBP not functional. 050207	The NIBP module message requires an object, but did not contain one	Internal malfunction. If the problem persists, replace the module.	Very low

Technical alarm and information messages

Condition	Cause	Remedy	Priority
NIBP not functional. 050208	The NIBP module object provided with the message could not be deserialized	Internal malfunction. If the problem persists, replace the module.	Very low
NIBP not functional. 050209	The NIBP module object could not be serialized	Internal malfunction. If the problem persists, replace the module.	Very low
NIBP not functional. 05020A	The NIBP module message is performing a request or action when the module state prohibits the request or action.	Internal malfunction. If the problem persists, replace the module.	Very low
NIBP not calibrated. 050503	Factory EEPROM checksum error on NIBP. Units internal configuration was corrupted	Internal malfunction. If the problem persists, replace the module.	Very low
NIBP not functional. 050504	User EEPROM checksum error. Configuration data which can be set in the user's configuration menu was damaged or lost on NIBP	Calibrate the NIBP Module. If problem persists, replace module.	Very low
NIBP not functional. 050505	Post failure of A/D convertor	Internal malfunction. If the problem persists, replace the module.	Very low
NIBP not calibrated. Calibrate the module. 050509	NIBP module calibration failure, the calibration signature is zero	Calibrate the NIBP module.	Very low
Invalid algorithm. Select correct algorithm and retry. 05050A	Invalid NIBP Algorithm. NIBP component software tried to configure the sensor in an illegal manner	Verify the correct algorithm. If the problem persists, replace the module.	Very low
NIBP not functional. 050513	Invalid NIBP initiation code	Internal malfunction. If the problem persists, replace the module.	Very low
Invalid patient mode. Select correct patient mode and retry. 050514	Invalid patient mode on NIBP. The NIBP component software tried to configure the sensor in an illegal manner	Verify correct patient mode. If the problem persists, replace the module.	Very low

Condition	Cause	Remedy	Priority
NIBP not functional. 050515	Invalid module configuration for NIBP	Internal malfunction. If the problem persists, replace the module.	Very low
NIBP not functional. 050516	NIBP module malfunction	Internal malfunction. If the problem persists, replace the module.	Very low
Ambient temperature out of range. Clear error and retry. 050517	Ambient temp out of range on NIBP	Restore device to normal temperature ranges and try again.	Very low
Low battery. Plug into outlet. 050518	The NIBP module power rail is too low	Plug device into an AC outlet to charge the battery.	Very low
Battery overcharged. Disconnect from outlet. 050519	The NIBP module power rail is too high.	Battery is overcharged. Remove from charging source.	Very low
NIBP not calibrated. Calibrate the module. 050601	NIBP failed to load safety processors calibration record from EEPROM	Calibrate the NIBP module. If the problem persists, replace the module.	Very low
NIBP not functional. 050602	NIBP safety processor failed ROM checksum	Internal malfunction. If the problem persists, replace the module.	Very low
NIBP not calibrated. Calibrate the module. 050603	NIBP safety processor not calibrated, missing calibration signature	Calibrate the NIBP module. If the problem persists, replace the module.	Very low
Cuff pressure limits exceeded. 050604	NIBP system failure. Overpressure	Restrict patient movement.	Medium
Premature auto cycle skipped. 050605	NIBP auto cycle skipped, SVRP requirement not satisfied	Cuff pressure is not below safety return pressure long enough to allow a cycle to occur.	Very low
Cuff pressure too high. Clear error to retry. 050606	NIBP cuff pressure above SVRP for too long	Verify cuff connections. If the problem persists, replace the module.	Medium
NIBP not functional. 050607	NIBP cannot clear the failsafe alerts	Internal malfunction. If the problem persists, replace the module.	Very low
NIBP not functional. 050608	NIBP safety processor has stopped responding	Internal malfunction. If the problem persists, replace the module.	Very low

Technical alarm and information messages

Condition	Cause	Remedy	Priority
Stat mode requested too soon. Clear to retry. 050609	NIBP excessive stat mode time. The time between readings is less than one minute and the readings plus time between readings result in the device taking over 15 minutes to complete the averaging cycle.	Internal malfunction. If the problem persists, replace the module.	Very low
Unable to determine NIBP; check connections and tubing for kinks. 05060A	NIBP transducers are not matched	The transducers are above 5 mmHg and the difference in pressure is greater than 40 mmHg. Check cuff for pinched or obstructed tubing. If the problem persists, replace the module.	Medium
NIBP not calibrated. Calibrate the module. 05060B	Factory EEPROM checksum error on NIBP. Units internal configuration was corrupted	Calibrate the NIBP module. If the problem persists, replace the module.	Very low
NIBP not functional. 05060C	NIBP command not implemented	Internal malfunction. If the problem persists, replace the module.	Very low
NIBP not functional. 05060D	NIBP wrong data count	Internal malfunction. If the problem persists, replace the module.	Very low
NIBP not functional. 05060E	NIBP data range error	Internal malfunction. If the problem persists, replace the module.	Very low
NIBP not functional. 05060F	NIBP no POST error to clear	Internal malfunction. If the problem persists, replace the module.	Very low
NIBP not functional. 050610	NIBP cannot clear this POST error	Internal malfunction. If the problem persists, replace the module.	Very low
NIBP not functional. 050611	NIBP command not command type	Internal malfunction. If the problem persists, replace the module.	Very low
NIBP not functional. 050612	NIBP communication timeout	Internal malfunction. If the problem persists, replace the module.	Very low
NIBP not functional. 050613	NIBP response header wrong	Internal malfunction. If the problem persists, replace the module.	Very low
NIBP not functional. 050614	NIBP response checksum wrong	Internal malfunction. If the problem persists, replace the module.	Very low

Condition	Cause	Remedy	Priority
NIBP not functional. 050615	Too much NIBP data was received	Internal malfunction. If the problem persists, replace the module.	Very low
NIBP not functional. 050616	NIBP FEPROM erase error	Internal malfunction. If the problem persists, replace the module.	Very low
NIBP not functional. 050617	NIBP FEPROM programming error	Internal malfunction. If the problem persists, replace the module.	Very low
NIBP not functional. 050618	Invalid NIBP target pressure	Internal malfunction. If the problem persists, replace the module.	Very low
Tube type does not match device configuration.	Tube type settings and actual type do not match	Change tube type setting to match actual tube type	Information
NIBP not functional. 05FF01	Unrecognized WACP parameter received from sensor	Internal malfunction. If the problem persists, replace the module.	Very low
NIBP not functional. 05FF02	Timeout waiting for sensor response	Internal malfunction. If the problem persists, replace the module.	Very low
NIBP not functional. 05FF03	Error deserializing the WACP message received from the sensor	Internal malfunction. If the problem persists, replace the module.	Very low
NIBP not functional. 05FF04	WACP stack send message failure	Internal malfunction. If the problem persists, replace the module.	Very low
NIBP not functional. 05FF05	Timeout waiting for asynchronous sensor message	Internal malfunction. If the problem persists, replace the module.	Very low
NIBP not functional. 05FF06	One or more undetermined numerics when reading status indicates OK	Check connections. Restrict patient movement.	Very low
NIBP not functional. 05FF07	Unrecognized sensor reading status code	Internal malfunction. If the problem persists, replace the module.	Very low
NIBP not functional. 05FF08	Sensor power up failure	Internal malfunction. If the problem persists, replace the module.	Very low
NIBP not functional. 05FF09	WACP rendezvous failure	Internal malfunction. If the problem persists, replace the module.	Very low
NIBP not functional. 05FF0A	Application firmware retrieval error during POST	Internal malfunction. If the problem persists, replace the module.	Very low

Condition	Cause	Remedy	Priority
NIBP not functional. 05FF0B	Upgrade .pim file is corrupt	Internal malfunction. If the problem persists, replace the module.	Very low
NIBP not functional. 05FF0C	Configured upgrade firmware directory cannot be accessed	Internal malfunction. If the problem persists, replace the module.	Very low
Device configuration issue. 05FF0D	Configured parameter (NIBP or SpO2) used in Intervals is missing	Use configured parameters for Intervals	Very low
NIBP not functional. 05FF0E	The NIBP sensor unexpectedly reset	Clear the error and try again	Very low
NIBP not functional. 05FF0F	The NIBP sensor firmware failed to upgrade	Internal malfunction. If the problem persists, replace the module.	Very low
Tube type does not match device configuration.	The tube type settings and the actual tube type do not match.	Change the tube type setting to match the actual tube type.	Information

SpO2 messages

General SpO2 messages



NOTE If the SpO2 measurement value does not change or remains blank after measuring for 30 seconds, replace the SpO2 sensor and extension cable.

Condition	Cause	Remedy	Priority
SpO2 not functional. 044900	SpO2 module is not responding	Internal Hardware malfunction in SpO2 module. Replace module.	Very low
SpO2 not functional. SpO2 rebooting. 044a00	SpO2 module is not responding	Informational error. Indicates that host software is attempting to clear an error by rebooting the SpO2 module. No action required.	Very low
SpO2 not functional. SpO2 rebooting. 044b00	The SpO2 module stopped sending data	Informational error. The host software is attempting to clear an error by rebooting the SpO2 module. No action required.	Very low
SpO2 not functional. SpO2 rebooting. 044c00	SpO2 received a packet with bad CRC from module	Informational error. The host has received a packet with bad CRC from the SpO2 module. The packet in question is ignored. No action required.	Very low

Condition	Cause	Remedy	Priority
SpO2 not functional. SpO2 rebooting. 044d00	The SpO2 power on self test failed	Internal hardware malfunction in SpO2 module. Replace the module.	Very low
SpO2 not functional. SpO2 rebooting. 044e00	The SpO2 power on self test timed out	Internal hardware malfunction in SpO2 module. Replace the module.	Very low

Masimo messages

Condition	Cause	Remedy	Priority
SpO2 cable is not connected. 040600	The SpO2 cable is not connected	Connect SpO2 cable. If the problem is still present, replace the SpO2 sensor. If the problem is still present, verify the module functionality by replacing the sensor with an applicable SpO2 tester. If the message persists, replace the module.	Very low
Replace the SpO2 cable. 040700	The SpO2 cable life has expired	Replace the SpO2 cable. If the problem is still present, verify module functionality by replacing the sensor with an applicable SpO2 tester. If the message persists, replace the module.	Very low
Replace the SpO2 cable. 040800	The SpO2 cable is incompatible with the monitor	Replace the SpO2 cable. If the problem is still present, verify module functionality by replacing the sensor with an applicable SpO2 tester. If the message persists, replace the module.	Very low
Replace the SpO2 cable. 040900	The SpO2 cable is not recognized by the monitor	Replace the SpO2 cable. If the problem is still present, verify module functionality by replacing the sensor with an applicable SpO2 tester. If the message persists, replace the module.	Very low
Replace the SpO2 cable. 040a00	The SpO2 cable is defective	Replace the SpO2 cable. If the problem is still present, verify module functionality by replacing the sensor with an applicable SpO2 tester. If the message persists, replace the module.	Very low

Technical alarm and information messages

Condition	Cause	Remedy	Priority
Attach SpO2 sensor to monitor. 040b00	The SpO2 sensor is not connected to the monitor	Connect SpO2 sensor. If the problem is still present, replace the SpO2 cable. If the problem is still present, verify the module functionality by replacing the sensor with an applicable SpO2 tester. If the message persists, replace the module.	Very low
The sensor has expired. Replace the SpO2 sensor. 040c00	The SpO2 sensor has expired	Replace SpO2 sensor. If the problem is still present, replace the SpO2 cable. If the problem is still present, verify the module functionality by replacing the sensor with an applicable SpO2 tester. If the message persists, replace the module.	Very low
Incompatible sensor. Replace the SpO2 sensor. 040d00	The SpO2 sensor is not recognized by the monitor	Replace SpO2 sensor. If the problem is still present, replace the SpO2 cable. If the problem is still present, verify the module functionality by replacing the sensor with an applicable SpO2 tester. If the message persists, replace the module.	Very low
Incompatible sensor. Replace the SpO2 sensor. 040e00	The SpO2 sensor is not recognized	Replace SpO2 sensor. If the problem is still present, replace the SpO2 cable. If the problem is still present, verify the module functionality by replacing the sensor with an applicable SpO2 tester. If the message persists, replace the module.	Very low
Replace the SpO2 sensor. 040f00	The SpO2 sensor is defective	Replace SpO2 sensor. If the problem is still present, replace the SpO2 cable. If the problem is still present, verify the module functionality by replacing the sensor with an applicable SpO2 tester. If the message persists, replace the module.	Very low

Condition	Cause	Remedy	Priority
Replace the SpO2 sensor. Replace the SpO2 cable. 041000	There was a fault with the SpO2 sensor and cable.	Check the sensor and cable connection. If the problem is still present, replace the SpO2 sensor. If the problem is still present, replace the cable. If the problem is still present, verify the module functionality by replacing the sensor with an applicable SpO2 tester. If the message persists replace the module.	Very low
Attach SpO2 sensor to monitor. 041100	An adhesive SpO2 sensor is not connected	Connect SpO2 sensor. If the problem is still present, replace the SpO2 cable. If the problem is still present, verify the module functionality by replacing the sensor with an applicable SpO2 tester. If the message persists, replace the module.	Very low
The sensor has expired. Replace the SpO2 sensor. 041200	The adhesive SpO2 sensor is expired	Replace SpO2 sensor. If the problem is still present, replace the SpO2 cable. If the problem is still present, verify the module functionality by replacing the sensor with an applicable SpO2 tester. If the message persists, replace the module.	Very low
Incompatible sensor. Replace the SpO2 sensor. 041300	The adhesive SpO2 sensor is incompatible	Replace SpO2 sensor. If the problem is still present, replace the SpO2 cable. If the problem is still present, verify the module functionality by replacing the sensor with an applicable SpO2 tester. If the message persists, replace the module.	Very low
Incompatible sensor. Replace the SpO2 sensor. 041400	The adhesive SpO2 sensor is not recognized	Replace SpO2 sensor. If the problem is still present, replace the SpO2 cable. If the problem is still present, verify the module functionality by replacing the sensor with an applicable SpO2 tester. If the message persists, replace the module.	Very low

Technical alarm and information messages

Condition	Cause	Remedy	Priority
Replace the SpO2 sensor. 041500	The adhesive SpO2 sensor is defective	Replace SpO2 sensor. If the problem is still present, replace the SpO2 cable. If the problem is still present, verify the module functionality by replacing the sensor with an applicable SpO2 tester. If the message persists, replace the module.	Very low
Searching for pulse signal. 041800	SpO2 pulse search	Pulse search is part of normal operation, and does not have an associated corrective action.	High
SpO2 interference detected. Clear to retry. 041900	SpO2 module interference detected.	Reapply the sensor to the patient. If problem is still present replace SpO2 sensor. If the problem is still present, replace cable. If the problem is still present, verify the module functionality by replacing the sensor with the applicable SpO2 tester. If the message persists, replace the module.	Very low
Low perfusion index. Clear to retry. 041a00	There is marginal SpO2 pulse quality or artifact.	Reapply the sensor to the patient. If problem still present replace SpO2 sensor, if problem still present replace cable, if problem still present verify module functionality by replacing the sensor with the applicable SpO2 tester. If the message persists replace the module.	Very low
Demo mode active. 041b00	The SpO2 parameter is in demo mode	None. ¹	Very low
Sensor not connected. Clear to retry. 041c00	Check the SpO2 sensor connection	Check the sensor and cable connection. If the problem is still present, replace the SpO2 sensor. If the problem is still present, replace the cable. If the problem is still present, verify the module functionality by replacing the sensor with an applicable SpO2 tester. If the message persists replace the module.	Very low

¹ Demo mode is reported when you plug a Masimo demo tool into the patient cable connector. This tool simulates a patient being connected, and is only used in a development environment. Because this tool simulates a patient without a patient actually being connected, it should NEVER be present in a clinical setting.

Condition	Cause	Remedy	Priority
SpO2 not functional. SpO2 rebooting. 041e00	There is an SpO2 raw queue overrun	A malfunction is detected. There are two possible causes of these failures. First, the power provided to the board is out of specification. In this case, the failure may be cleared once the underlying cause is removed. Second, the board has an actual hardware failure and recovery is not possible. It is recommended that the SpO2 module be replaced, and if problem is still present replace the monitor's main board.	Very low
SpO2 not functional. SpO2 rebooting. 041f00	There is an SpO2 hardware failure	A malfunction is detected. There are two possible causes of these failures. First, the power provided to the board is out of specification. In this case, the failure may be cleared once the underlying cause is removed. Second, the board has an actual hardware failure and recovery is not possible. It is recommended that the SpO2 module be replaced, and if problem is still present replace the monitor's main board.	Very low
SpO2 not functional. SpO2 rebooting. 042000	There is an SpO2 MCU failure	A malfunction is detected. There are two possible causes of these failures. First, the power provided to the board is out of specification. In this case, the failure may be cleared once the underlying cause is removed. Second, the board has an actual hardware failure and recovery is not possible. It is recommended that the SpO2 module be replaced, and if problem is still present replace the monitor's main board.	Very low
SpO2 not functional. SpO2 rebooting. 042100	There is an SpO2 watchdog failure	A malfunction is detected. There are two possible causes of these failures. First, the power provided to the board is out of specification. In this case, the failure may be cleared once the underlying cause is removed. Second, the board has an actual hardware failure and recovery is not possible. It is recommended that the SpO2 module be replaced, and if problem is still present replace the monitor's main board.	Very low

Condition	Cause	Remedy	Priority
SpO2 not functional. SpO2 rebooting. 042200	SpO2 not functional or there is an invalid SpO2 board type	A malfunction is detected. There are two possible causes of these failures. First, the power provided to the board is out of specification. In this case, the failure may be cleared once the underlying cause is removed. Second, the board has an actual hardware failure and recovery is not possible. It is recommended that the SpO2 module be replaced, and if problem is still present replace the monitor's main board.	Very low
SpO2 not functional. SpO2 rebooting. 042300	There is an invalid SpO2 master control state	A malfunction is detected. There are two possible causes of these failures. First, the power provided to the board is out of specification. In this case, the failure may be cleared once the underlying cause is removed. Second, the board has an actual hardware failure and recovery is not possible. It is recommended that the SpO2 module be replaced, and if problem is still present replace the monitor's main board.	Very low
SpO2 not functional. SpO2 rebooting. 042400	There is an SpO2 SRAM transfer failure	A malfunction is detected. There are two possible causes of these failures. First, the power provided to the board is out of specification. In this case, the failure may be cleared once the underlying cause is removed. Second, the board has an actual hardware failure and recovery is not possible. It is recommended that the SpO2 module be replaced, and if problem is still present replace the monitor's main board.	Very low
SpO2 not functional. SpO2 rebooting. 042500	There is an SpO2 SRAM task queue overrun	A malfunction is detected. There are two possible causes of these failures. First, the power provided to the board is out of specification. In this case, the failure may be cleared once the underlying cause is removed. Second, the board has an actual hardware failure and recovery is not possible. It is recommended that the SpO2 module be replaced, and if problem is still present replace the monitor's main board.	Very low

Condition	Cause	Remedy	Priority
SpO2 not functional. SpO2 rebooting. 042600	There is an SpO2 database failure	A malfunction is detected. There are two possible causes of these failures. First, the power provided to the board is out of specification. In this case, the failure may be cleared once the underlying cause is removed. Second, the board has an actual hardware failure and recovery is not possible. It is recommended that the SpO2 module be replaced, and if problem is still present replace the monitor's main board.	Very low
SpO2 not functional. SpO2 rebooting. 042700	There is an invalid SpO2 flash memory device	A malfunction is detected. There are two possible causes of these failures. First, the power provided to the board is out of specification. In this case, the failure may be cleared once the underlying cause is removed. Second, the board has an actual hardware failure and recovery is not possible. It is recommended that the SpO2 module be replaced, and if problem is still present replace the monitor's main board.	Very low
SpO2 not functional. SpO2 rebooting. 042800	There is an SpO2 anode voltage configuration failure	A malfunction is detected. There are two possible causes of these failures. First, the power provided to the board is out of specification. In this case, the failure may be cleared once the underlying cause is removed. Second, the board has an actual hardware failure and recovery is not possible. It is recommended that the SpO2 module be replaced, and if problem is still present replace the monitor's main board.	Very low
SpO2 not functional. SpO2 rebooting. 042900	There is a problem with the SpO2 analog ground	A malfunction is detected. There are two possible causes of these failures. First, the power provided to the board is out of specification. In this case, the failure may be cleared once the underlying cause is removed. Second, the board has an actual hardware failure and recovery is not possible. It is recommended that the SpO2 module be replaced, and if problem is still present replace the monitor's main board.	Very low

Condition	Cause	Remedy	Priority
SpO2 not functional. SpO2 rebooting. 042a00	There is a problem with the SpO2 digital ground	A malfunction is detected. There are two possible causes of these failures. First, the power provided to the board is out of specification. In this case, the failure may be cleared once the underlying cause is removed. Second, the board has an actual hardware failure and recovery is not possible. It is recommended that the SpO2 module be replaced, and if problem is still present replace the monitor's main board.	Very low
SpO2 not functional. SpO2 rebooting. 042b00	There is a problem with the SpO2 LED ground	A malfunction is detected. There are two possible causes of these failures. First, the power provided to the board is out of specification. In this case, the failure may be cleared once the underlying cause is removed. Second, the board has an actual hardware failure and recovery is not possible. It is recommended that the SpO2 module be replaced, and if problem is still present replace the monitor's main board.	Very low
SpO2 not functional. SpO2 rebooting. 042c00	There is a problem with the SpO2 reference voltage	A malfunction is detected. There are two possible causes of these failures. First, the power provided to the board is out of specification. In this case, the failure may be cleared once the underlying cause is removed. Second, the board has an actual hardware failure and recovery is not possible. It is recommended that the SpO2 module be replaced, and if problem is still present replace the monitor's main board.	Very low
SpO2 not functional. SpO2 rebooting. 042d00	There is a problem with the SpO2 DSP core voltage	A malfunction is detected. There are two possible causes of these failures. First, the power provided to the board is out of specification. In this case, the failure may be cleared once the underlying cause is removed. Second, the board has an actual hardware failure and recovery is not possible. It is recommended that the SpO2 module be replaced, and if problem is still present replace the monitor's main board.	Very low

Condition	Cause	Remedy	Priority
SpO2 not functional. SpO2 rebooting. 042e00	There is a problem with the SpO2 filtered input voltage	A malfunction is detected. There are two possible causes of these failures. First, the power provided to the board is out of specification. In this case, the failure may be cleared once the underlying cause is removed. Second, the board has an actual hardware failure and recovery is not possible. It is recommended that the SpO2 module be replaced, and if problem is still present replace the monitor's main board.	Very low
SpO2 not functional. SpO2 rebooting. 042f00	There is a problem with the SpO2 DSP I/O voltage	A malfunction is detected. There are two possible causes of these failures. First, the power provided to the board is out of specification. In this case, the failure may be cleared once the underlying cause is removed. Second, the board has an actual hardware failure and recovery is not possible. It is recommended that the SpO2 module be replaced, and if problem is still present replace the monitor's main board.	Very low
SpO2 not functional. SpO2 rebooting. 043000	There is a problem with the SpO2 positive detector voltage	A malfunction is detected. There are two possible causes of these failures. First, the power provided to the board is out of specification. In this case, the failure may be cleared once the underlying cause is removed. Second, the board has an actual hardware failure and recovery is not possible. It is recommended that the SpO2 module be replaced, and if problem is still present replace the monitor's main board.	Very low
SpO2 not functional. SpO2 rebooting. 043100	There is a problem with the SpO2 negative detector voltage	A malfunction is detected. There are two possible causes of these failures. First, the power provided to the board is out of specification. In this case, the failure may be cleared once the underlying cause is removed. Second, the board has an actual hardware failure and recovery is not possible. It is recommended that the SpO2 module be replaced, and if problem is still present replace the monitor's main board.	Very low

Condition	Cause	Remedy	Priority
SpO2 not functional. SpO2 rebooting. 043200	There is a problem with the SpO2 positive LED Voltage	A malfunction is detected. There are two possible causes of these failures. First, the power provided to the board is out of specification. In this case, the failure may be cleared once the underlying cause is removed. Second, the board has an actual hardware failure and recovery is not possible. It is recommended that the SpO2 module be replaced, and if problem is still present replace the monitor's main board.	Very low
SpO2 not functional. SpO2 rebooting. 043300	There is a problem with the SpO2 LED drive voltage	A malfunction is detected. There are two possible causes of these failures. First, the power provided to the board is out of specification. In this case, the failure may be cleared once the underlying cause is removed. Second, the board has an actual hardware failure and recovery is not possible. It is recommended that the SpO2 module be replaced, and if problem is still present replace the monitor's main board.	Very low
SpO2 not functional. SpO2 rebooting. 043400	There is a problem with the SpO2 positive preamp voltage	A malfunction is detected. There are two possible causes of these failures. First, the power provided to the board is out of specification. In this case, the failure may be cleared once the underlying cause is removed. Second, the board has an actual hardware failure and recovery is not possible. It is recommended that the SpO2 module be replaced, and if problem is still present replace the monitor's main board.	Very low
SpO2 not functional. SpO2 rebooting. 043500	There is a problem with the SpO2 Sensor ID	A malfunction is detected. There are two possible causes of these failures. First, the power provided to the board is out of specification. In this case, the failure may be cleared once the underlying cause is removed. Second, the board has an actual hardware failure and recovery is not possible. It is recommended that the SpO2 module be replaced, and if problem is still present replace the monitor's main board.	Very low

Condition	Cause	Remedy	Priority
SpO2 not functional. SpO2 rebooting. 043600	There is a problem with the SpO2 thermistor	A malfunction is detected. There are two possible causes of these failures. First, the power provided to the board is out of specification. In this case, the failure may be cleared once the underlying cause is removed. Second, the board has an actual hardware failure and recovery is not possible. It is recommended that the SpO2 module be replaced, and if problem is still present replace the monitor's main board.	Very low
SpO2 not functional. SpO2 rebooting. 043700	There is a problem with the SpO2 LED current	A malfunction is detected. There are two possible causes of these failures. First, the power provided to the board is out of specification. In this case, the failure may be cleared once the underlying cause is removed. Second, the board has an actual hardware failure and recovery is not possible. It is recommended that the SpO2 module be replaced, and if problem is still present replace the monitor's main board.	Very low
SpO2 not functional. SpO2 rebooting. 043800	There is a problem with the SpO2 preamp	A malfunction is detected. There are two possible causes of these failures. First, the power provided to the board is out of specification. In this case, the failure may be cleared once the underlying cause is removed. Second, the board has an actual hardware failure and recovery is not possible. It is recommended that the SpO2 module be replaced, and if problem is still present replace the monitor's main board.	Very low
SpO2 not functional. SpO2 rebooting. 044300	The SpO2 module received bad packet	There is an internal software malfunction in the main PCBA. Update the software. If the problem persists, replace the module.	Very low
SpO2 not functional. SpO2 rebooting. 044400	The SpO2 module received an invalid command	There is an internal software malfunction in the main PCBA. Update the software. If the problem persists, replace the module.	Very low

Technical alarm and information messages

Condition	Cause	Remedy	Priority
SpO2 not functional. SpO2 rebooting. 044500	The SpO2 module received a command that would result in more output than the baud rate can support	There is an internal software malfunction in the main PCBA. Update the software. If the problem persists, replace the module.	Very low
SpO2 not functional. SpO2 rebooting. 044600	The SpO2 module received a command that requires an application that is not present	There is an internal software malfunction in the main PCBA. Update the software. If the problem persists, replace the module.	Very low
SpO2 not functional. SpO2 rebooting. 044700	The SpO2 module received a command while still locked	There is an internal software malfunction in the main PCBA. Update the software. If the problem persists, replace the module.	Very low
SpO2 low signal quality. Check sensor. 044F00	SpO2 low Sat signal quality	Reapply the sensor to the patient. If the problem is still present, replace the SpO2 sensor. If the problem is still present, replace the cable. If the problem is still present, verify module functionality by replacing the sensor with an applicable SpO2 tester. If the message persists, replace the module.	Very low
SpO2 low signal quality. Check sensor. 045000	Low PR confidence	Reapply the sensor to the patient. If the problem is still present, replace the SpO2 sensor. If the problem is still present, replace the cable. If the problem is still present, verify module functionality by replacing the sensor with an applicable SpO2 tester. If the message persists, replace the module.	Very low
SpO2 low signal quality. Check sensor. 045100	Low PI confidence	Reapply the sensor to the patient. If the problem is still present, replace the SpO2 sensor. If the problem is still present, replace the cable. If the problem is still present, verify module functionality by replacing the sensor with an applicable SpO2 tester. If the message persists, replace the module.	Very low

Condition	Cause	Remedy	Priority
SpO2 sensor near expiration. Replace the SpO2 sensor. 045200	SpO2 cable near expiration.	Replace SpO2 cable, if problem still present verify module functionality by replacing the sensor with the applicable SpO2 tester. If the message persists replace the module.	Very low
SpO2 sensor near expiration. Replace the SpO2 sensor. 045300	SpO2 sensor near expiration.	Replace SpO2 sensor, if problem still present replace cable, if problem still present verify module functionality by replacing the sensor with the applicable SpO2 tester. If the message persists replace the module.	Very low
SpO2 sensor near expiration. Replace the SpO2 sensor. 045400	SpO2 adhesive sensor near expiration.	Replace SpO2 sensor, if problem still present replace cable, if problem still present verify module functionality by replacing the sensor with the applicable SpO2 tester. If the message persists replace the module.	Very low
Masimo programming mode started.	Masimo upgrade tool was connected and programming mode was requested by the tool. Masimo programming mode started.	Masimo programming mode started.	Information
Masimo programming mode complete.	Masimo programming mode complete.	Masimo programming mode complete.	Information
Masimo programming mode failed.	Masimo programming mode failed <error condition>.	Retry programming.	Information

Nellcor messages

Condition	Cause	Remedy	Priority
Sensor not connected. Clear to retry. 043900	The SpO2 sensor is not connected	Connect SpO2 sensor. If the problem is still present, replace the SpO2 cable. If the problem is still present, verify the module functionality by replacing the sensor with an applicable SpO2 tester. If the message persists, replace the module.	Very low

Technical alarm and information messages

Condition	Cause	Remedy	Priority
Searching for pulse signal. 043a00	SpO2 pulse search	None ²	High
SpO2 interference detected. Clear to retry. 043c00	SpO2 module interference detected.	Reapply the sensor to the patient. If the problem is still present, replace the SpO2 sensor. If the problem is still present, replace the cable. If the problem is still present, verify module functionality by replacing the sensor with an applicable SpO2 tester. If the message persists, replace the module.	Very low
SpO2 not functional. SpO2 rebooting. 043d00	SpO2 module hardware error	A module hardware error is detected. Replace module.	Very low
SpO2 not functional. SpO2 rebooting. 043e00	SpO2 module hardware error	A module hardware error is detected. Replace module.	Very low
SpO2 rebooting. 043f00	SpO2 module software error	A module software error is detected. Wait for module to reset itself.	Very low
SpO2 not functional. SpO2 rebooting. 044000	SpO2 module received a bad message	Error indicates bug in main board software. If the problem persists, attempt to update the software or replace the module.	Very low
Replace the SpO2 sensor. 044100	SpO2 defective sensor.	Replace the SpO2 sensor. If the problem is still present, replace the SpO2 sensor a second time. If the problem is still present, replace the cable. If the problem is still present, verify module functionality by replacing the sensor with an applicable SpO2 tester. If the message persists, replace the module.	Very low
SpO2 not functional. SpO2 rebooting. 044200	The SpO2 module received a bad message	Error indicates bug in main board software. If the problem persists, attempt to update the software or replace the module.	Very low

² Pulse search is a normal part of operation and does not have an associated corrective action.

Temperature messages

SureTemp thermometer messages

Condition	Cause	Remedy	Priority
Alarm limit exceeded. Temperature High. 03000D	Temperature exceeded the rated measurement range	N/A	Medium
Alarm limit exceeded. Temperature Low. 03000E	Temperature is below the rated measurement range	N/A	Medium
Temperature not functional. 030105	WACP message CRC mismatch on temperature module	Internal malfunction. If the problem persists, replace the module.	Very low
Temperature not functional. 030201	This message is not implemented by the temperature module	Internal malfunction. If the problem persists, replace the module.	Very low
Temperature not functional. 030202	This message is not supported by the temperature module	Internal malfunction. If the problem persists, replace the module.	Very low
Temperature not functional. 030203	The temperature module has run out of memory.	Internal malfunction. If the problem persists, replace the module.	Very low
Temperature not functional. 030204	No parameter provided for the specified message.	Internal malfunction. If the problem persists, replace the module.	
Temperature not functional. 030205	The temperature module received a invalid parameter	Internal malfunction. If the problem persists, replace the module.	Very low
Temperature not functional. 030206	The parameter provided by the temperature module is outside of the allowable range for the specified message.	Internal malfunction. If the problem persists, replace the module.	Very low
Temperature not functional. 030207	The temperature module message requires an object, but did not contain one.	Internal malfunction. If the problem persists, replace the module.	Very low
Temperature not functional. 030208	The temperature module object provided with the message could not be deserialized.	Internal malfunction. If the problem persists, replace the module.	Very low

Technical alarm and information messages

Condition	Cause	Remedy	Priority
Temperature not functional. 030209	The temperature module object could not be serialized.	Internal malfunction. If the problem persists, replace the module.	Very low
Temperature not functional. 03020A	The temperature module message is performing a request/action when the module state prohibits the request/action.	Internal malfunction. If the problem persists, replace the module.	Very low
Temperature not functional. 03020B	The temperature module requested item is not currently available due to the module state.	Internal malfunction. If the problem persists, replace the module.	Very low
Temperature not functional. 030503	The temperature module factory settings, and calibration information is corrupt.	Internal malfunction. If the problem persists, replace the module.	Very low
Temperature not functional. 030504	The temperature module user settings are corrupt.	Internal malfunction. If the problem persists, replace the module.	Very low
Temperature not functional. 030509	The temperature module calibration is not set.	Internal malfunction. If the problem persists, replace the module.	Very low
Temperature not functional. 03050C	The temperature module error log is corrupt.	Internal malfunction. If the problem persists, replace the module.	Very low
Temperature not functional. 030516	A hardware malfunction on the temperature module has been detected.	Internal malfunction. If the problem persists, replace the module.	Very low
Temperature not functional. 030518	The temperature module power rail is too low.	Internal malfunction. If the problem persists, replace the module.	Very low
Temperature not functional. 030519	The temperature module power rail is too high.	Internal malfunction. If the problem persists, replace the module.	Very low
Unable to detect new temperature. Retry measurement. 03051A	The temperature module reference voltage circuit was detected to be under voltage or unstable.	Internal malfunction. If the problem persists, replace the module.	Very low

Condition	Cause	Remedy	Priority
Ambient temperature out of range. Clear to retry. 030801	The temperature module measurement is below the allowable temperature values and beyond the low ambient or patient limits.	Verify conditions are greater than 50 °F or 10 °C. If conditions are valid and the problem persists, replace the probe. If the problem still persists, replace the module.	Very low
Ambient temperature out of range. Clear to retry. 030802	The temperature module measurement is above the allowable temperature values and beyond the high ambient or patient limits.	Verify conditions are less than 104 °F or 40 °C. If conditions are valid and the problem persists, replace the probe. If the problem still persists, replace the module.	Very low
Temperature not functional. 030803	The temperature module internal calibration resistor (RCAL) on the board is damaged or contaminated (pulse too long).	Internal malfunction. If the problem persists, replace the module.	Very low
Temperature not functional. 030804	The temperature module internal calibration resistor (RCAL) on the board is damaged or contaminated (pulse too short).	Internal malfunction. If the problem persists, replace the module.	Very low
Temperature not functional. 030805	The temperature module internal circuit validation resistor (PTB) on the board is damaged (value is over).	Internal malfunction. If the problem persists, replace the module.	Very low
Temperature not functional. 030806	The temperature module internal circuit validation resistor (PTB) on the board is damaged (value is under).	Internal malfunction. If the problem persists, replace the module.	Very low
Ambient temperature out of range. Clear to retry. 030807	The temperature module A/D measurement timed out	Verify conditions are greater than 50 °F or 10 °C. If conditions are valid and the problem persists, replace the probe. If the problem still persists, replace the module.	Very low
Replace temperature probe. 030808	The temperature module probe was not characterized/calibrated	Probe malfunction. Replace the probe. If the problem persists, replace the module.	Very low

Technical alarm and information messages

Condition	Cause	Remedy	Priority
Temperature not functional. 03080A	The temperature module has a problem saving to the monitor EEPROM in biotech mode	Internal malfunction. If the problem persists, replace the module.	Very low
Temperature not functional. 03080B	The temperature module error detection mechanism detected an error	Internal malfunction. If the problem persists, replace the module.	Very low
Replace temperature probe. 03080C	The temperature module probe error detection mechanism detected an error	Probe malfunction. Replace probe. If the problem persists, replace the module.	Very low
Temperature not functional. 03080D	The temperature module log error detection mechanism detected an error	Probe malfunction. Replace probe. If the problem persists, replace the module.	Very low
Temperature not functional. 03080E	The temperature module calibration error detection mechanism detected an error	Probe malfunction. Replace probe. If the problem persists, replace the module.	Very low
Connect temperature probe. 03080F	The temperature module detected no probe connected	Probe malfunction. Replace probe. If the problem persists, replace the module.	Very low
Replace temperature probe. 030810	The temperature module cannot read the probe's EEPROM correctly.	Probe malfunction. Replace probe. If the problem persists, replace the module.	Very low
Temperature not functional. 030811	The temperature module has an invalid events index	Internal malfunction. If the problem persists, replace the module.	Very low
Temperature not functional. 030812	There is a problem reading the temperature module EEPROM or saving to the monitor EEPROM in biotech mode.	Internal malfunction. If the problem persists, replace the module.	Very low
Replace temperature probe. 030813	The temperature module has a problem reading the probe EEPROM.	Probe malfunction. Replace probe. If the problem persists, replace the module.	Very low
Temperature not functional. 030814	The temperature module TEMP CONFIG ACQUIRE FAILURE	Internal malfunction. If the problem persists, replace the module.	Very low

Condition	Cause	Remedy	Priority
Temperature not functional. 030815	The temperature module TEMP CONFIG RELEASE FAILURE	Internal malfunction. If the problem persists, replace the module.	Very low
Temperature not functional. 030816	The temperature module TEMP CONFIG INVALID PTR FAILURE	Internal malfunction. If the problem persists, replace the module.	Very low
Temperature not functional. 030817	The temperature module internal error. EEPROM not initialized	Internal malfunction. If the problem persists, replace the module.	Very low
Unable to detect new temperature. Retry measurement. 030818	The temperature module heater indicates on when turned off.	Probe malfunction. Replace probe. If the problem persists, replace the module.	Very low
Unable to detect new temperature. Retry measurement. 030819	The temperature module heater indicates off when turned on.	Probe malfunction. Replace probe. If the problem persists, replace the module.	Very low
Temperature not functional. 03081A	The temperature module HTR_Q is on and HTRC is off but still has voltage.	Internal malfunction. If the problem persists, replace the module.	Very low
Temperature not functional. 03081B	The temperature module HTR_Q is tri-stated with HTRC enabled and has heater power.	Internal malfunction. If the problem persists, replace the module.	Very low
Temperature not functional. 03081C	The temperature module turned Q&C on and the heater voltage is not high enough.	Internal malfunction. If the problem persists, replace the module.	Very low
Temperature not functional. 03081D	The temperature module heater hardware failsafe should have turned off but did not.	Internal malfunction. If the problem persists, replace the module.	Very low
Replace temperature probe. 03081E	The temperature module probe is above 112°F or 44.4°C.	Probe malfunction. Replace probe. If the problem persists, replace the module.	Very low
Replace temperature probe. 03081F	The temperature module has excessive heater energy	Probe malfunction. Replace probe. If the problem persists, replace the module.	Very low
Temperature not functional. 030820	Temperature module host interface error	Internal malfunction. If the problem persists, replace the module.	Very low

Technical alarm and information messages

Condition	Cause	Remedy	Priority
Ambient temperature out of range. Clear to retry. 030821	The temperature module is over ambient 45 °C temp	Verify conditions are less than 104 °F or 40 °C. If conditions are valid and the problem persists, replace the probe. If the problem still persists, replace the module.	Very low
Ambient temperature out of range. Clear to retry. 030822	The temperature module is under ambient temp	Verify conditions are greater than 50 °F or 10 °C. If conditions are valid and the problem persists, replace the probe. If the problem still persists, replace the module.	Very low
Temperature not functional. 030823	The temperature module has an invalid SureTemp algorithm	Internal malfunction. If the problem persists, replace the module.	Very low
Temperature not functional. 030824	The temperature module is over max battery volts	Internal malfunction. If the problem persists, replace the module.	Very low
Temperature not functional. 030825	The temperature module is under min battery volts	Internal malfunction. If the problem persists, replace the module.	Very low
Temperature not functional. 030826	The temperature module battery volts not set	Internal malfunction. If the problem persists, replace the module.	Very low
Temperature not functional. 030827	The temperature module predict algorithm is not set	Internal malfunction. If the problem persists, replace the module.	Very low
Temperature not functional. 030828	The temperature module ambient temp is not set	Internal malfunction. If the problem persists, replace the module.	Very low
Replace temperature probe. 030829	The temperature module has a non-responsive probe. The thermistor has pulled away from the tip or the heater is broken.	Probe malfunction. Replace probe. If the problem persists, replace the module.	Very low
Replace temperature probe. 03082A	The temperature module is experiencing bad probe gain	Probe malfunction. Replace probe. If the problem persists, replace the module.	Very low
Replace temperature probe. 03082B	The temperature module has a bad probe response value	Probe malfunction. Replace probe. If the problem persists, replace the module.	Very low
Temperature not functional. 03C800	The temperature module is not functional	Internal malfunction. If the problem persists, replace the module.	Very low

Condition	Cause	Remedy	Priority
Temperature not functional. 03C900	Unable to deserialize messages from the temperature module	Internal malfunction. If the problem persists, replace the module.	Very low
Temperature not functional. 03CA00	Unsupported message received from the Temperature module	Internal malfunction. If the problem persists, replace the module.	Very low
Temperature not functional. 03CB00	Unable to send message to the Temperature module	Internal malfunction. If the problem persists, replace the module.	Very low
Temperature not functional. 03CC00	Temperature module communication times out	Internal malfunction. If the problem persists, replace the module.	Very low
Temperature not functional. 03CD00	Failed to upgrade the temperature module	Internal malfunction. If the problem persists, replace the module.	Very low
Temperature not functional. 03CE00	Unable to read PIM file	Retry the device update.	Very low
Temperature not functional. 03CE01	Upgrade file directory could not be accessed	Retry the device update.	Very low
Direct mode reading timed out	Direct mode reading times out	Direction mode reading times out	Information
Tissue contact lost.	Lost tissue contact while attempting to acquire a temperature measurement or acquired measurement was performed with limited tissue contact.	Check the tissue contact and try the measurement again.	Information
Temperature module reset. 03D000	Temperature sensor reset unexpectedly	Information status message; press OK button to dismiss.	Very low

Patient and Clinician data messages

Condition	Cause	Remedy	Priority
Patient list update successful.	The patient list was successfully updated from the host system.	Information status message; press OK button to dismiss.	Information

Technical alarm and information messages

Condition	Cause	Remedy	Priority
Patient list query timeout exceeded.	The patient list retrieval was aborted as it exceeded the maximum allowed time.	Check your network connectivity settings and ensure the device location ID matches your host system.	Information
Unable to retrieve list.	Unable to retrieve or update the patient list.	Check your network connectivity settings and ensure the device location ID matches your host system.	Information
Your login time has expired. Re-enter your password.	Single Sign-on login time expired.	Password authentication is required.	Information
Your login time has expired. Re-enter your PIN.	Single Sign-on login time expired.	PIN authentication is required.	Information
Clinician logout is not allowed during intervals.	Clinician logout not allowed when intervals are running.	Stop intervals program and attempt logout again.	Information
Unable to identify clinician. No provider configured at host.	Clinician authentication failure	Information status message; press OK button to dismiss.	Information
Unable to identify clinician. Security provider error.	Clinician authentication failure	Information status message; press OK button to dismiss.	Information
Unable to identify clinician. User not found.	Clinician authentication failure	Information status message; press OK button to dismiss.	Information
Unable to identify clinician. Invalid ID or system password.	Clinician authentication failure	Information status message; press OK button to dismiss.	Information
Unable to identify clinician. Account disabled/expired.	Clinician authentication failure	Information status message; press OK button to dismiss.	Information
Unable to identify clinician. Password expired/reset required.	Clinician authentication failure	Information status message; press OK button to dismiss.	Information
Unable to identify clinician. Group membership error.	Clinician authentication failure	Information status message; press OK button to dismiss.	Information
Unable to identify clinician.	Clinician authentication failure	Information status message; press OK button to dismiss.	Information

Condition	Cause	Remedy	Priority
Unable to identify patient.	Patient authentication failure	Information status message; press OK button to dismiss.	Information
Badge not accepted. Rescan badge on the login screen.	Badge scan not accepted	Rescan badge on the login screen.	Very Low
Database schema out of date; recreating.	The database was cleared due to a schema update	Information status message; press OK button to dismiss.	Information
Database is unreadable during startup; recreating. 1F0001	The database was unreadable during startup	Press OK button to dismiss.	Very low
Error accessing PDM database; restarting PDM. 1F0002	Error accessing PDM database; restarting PDM	Press OK button to dismiss.	Very low
Maximum number of patient records + Oldest record overwritten.	Maximum number of patient records + Oldest record overwritten	Information status message; press OK button to dismiss.	Information
No data saved.	A manual save is not allowed	Information status message; press OK button to dismiss.	Information
Save successful.	Log saved successfully	Information status message; press OK button to dismiss.	Information
Patient ID required to save data.	A Patient ID is required to save data	Information status message; press OK button to dismiss.	Information
Patient ID required to start intervals.	A Patient ID is required to start intervals	Information status message; press OK button to dismiss.	Information
Clinician ID required to save data.	A Clinician ID is required to save data	Information status message; press OK button to dismiss.	Information
Clinician ID required to start intervals.	A Clinician ID is required to start intervals	Information status message; press OK button to dismiss.	Information
Patient ID match required to save data.	A Patient ID match is required to save data	Information status message; press OK button to dismiss.	Information
Patient ID match required to start intervals.	A Patient ID match is required to start intervals	Information status message; press OK button to dismiss.	Information
Clinician ID match required to save data.	A Clinician ID match is required to save data	N/A	Information

Technical alarm and information messages

Condition	Cause	Remedy	Priority
Clinician ID match required to start intervals.	A Clinician ID match is required to start intervals	N/A	Information
Unable to auto save.	The device was unable to auto save	Information status message; press OK button to dismiss.	Information
Barcode scan not accepted.	Barcode scanning is not available	Information status message; press OK button to dismiss.	Information
Invalid NIBP interval parameter during interval capture.	An invalid interval parameter was detected.	Information status message; press OK button to dismiss.	Information
Save successful.	The auto save is successful	Information status message; press OK button to dismiss.	Information
Unsent records: N of M	There are unsent records waiting when the device is powered down	Information status message; press OK button to dismiss.	Information
Invalid SpO2 interval parameter during interval capture.	An invalid interval parameter was detected. SpO2 intervals are enabled or SpO2 sensor was removed	Either stop the intervals or reattach the SpO2 sensor. Information status message; press OK button to dismiss.	Information

Radio messages

Condition	Cause	Remedy	Priority
Radio not functional. 350000	Internal software error on the radio	Check for a software update and apply it. If still present, replace the radio.	Very low
Lost network communications. 350400	Radio lost association	Ensure the access point is still powered on and in range. If your facility has turned off radio alarms, an Information message will display instead of an alarm message.	Very low
Lost network communications.	Radio lost association	Ensure the access point is still powered on and in range. Ensure the radio/network settings are configured correctly.	Information

Condition	Cause	Remedy	Priority
Invalid radio configuration. Reconfigure and try again. 350700	Radio configuration is invalid.	Check the radio configuration. If problem is still present, reset the radio to factory defaults. If the problem persists, check for software update and apply it. If still present, replace the radio.	Very low
Radio certificate is out of date. 350800	Indicates that the radio certificate is out of date. The date, time, or time zone may be incorrect causing the certificate to not be in the valid date range.	Date, time, or time zone needs to be set properly, or the certificate needs to be updated.	Very low

Connectivity messages

Condition	Cause	Remedy	Priority
Error in record. Try again.	Connectivity NACK received for NRS/ECS/CS/NCE	NRS/ECS/CS/NCE NACK that is record specific and can be fixed by a clinician in the next record	Information
Unable to obtain wired device IP address. 210000	No wired connection	Verify DHCP functionality and configuration.	Very low
Network not found; check network cable connection. 210100	Lost ethernet DHCP address	Check wired connection into device then verify DHCP functionality and configuration.	Very low
Communication error with host. 1A0000	Communication timeout failure with external Host	Verify the external host services are loaded and started on the server. If the problem persists, check for available software upgrades of the monitor or the system.	Very low
Data rejected. CRC mismatch. 1A0001	External Host NACK - The WACP stack has detected a CRC mismatch in the message	Check the data and try again. If the problem persists, contact your system administrator.	Very low
Data rejected. Unsupported message. 1A0002	External Host NACK - The host does not support the message/object.	Check the monitor and try again. If the problem persists, contact your system administrator.	Very low
Data rejected. Invalid parameter. 1A0003	External Host NACK - The message has an invalid parameter	Check the data and try again. If the problem persists, contact your system administrator.	Very low

Technical alarm and information messages

Condition	Cause	Remedy	Priority
Data rejected. Deserialize the object. 1A0004	External Host NACK - The device failed to deserialize the object	Check the data and try again. If the problem persists, contact your system administrator.	Very low
Data rejected. Unsupported message. 1A0005	External Host NACK - The host is in a state that can't accept the message	Check the data and try again. If the problem persists, contact your system administrator.	Very low
Data rejected. Patient ID required. 1A0006	External Host NACK - The message has a missing patient ID	Add the patient ID to the record.	Very low
Data rejected. Clinician ID required. 1A0007	External Host NACK - The message has a missing clinician ID	Add the clinician ID to the record.	Very low
Data rejected. Time mismatch. 1A0008	External Host NACK - The message has a mismatch time	Ensure the date or time on the monitor and the server match.	Very low
Unable to establish network communications. 1A0009	No network connection is available	Connect the device to an active network so that the clinician ID can be imported.	Very low
No connection for send.	No connection for send.	Information status message; press OK button to dismiss.	Information
Send successful.	Data was successfully sent	Information status message; press OK button to dismiss.	Information
Send not successful.	Send not successful.	Information status message; press OK button to dismiss.	Information
Client certificate used for Service Host connection expired.	Client certificate used for EMR Host connection expired.	Client certificate used for Service Host connection expired.	Information
Client certificate used for EMR Host connection expired. 1A000B	Client certificate used for EMR Host connection expired.	Update the client certificate for Service Host connection.	Very low
Unable to connect due to invalid client certificate. 1A000A	Unable to connect due to invalid client certificate	Update the client certificate.	Very Low
Client certificate for Service Host expires within 30 days.	Client certificate used for Service Host connection expires within 30 days.	Update the client certificate for Service Host connection.	Information
Client certificate expires within 30 days.	Client certificate expires within 30 days.	Client certificate used for EMR Host connection expires within 30 days.	Information

Condition	Cause	Remedy	Priority
Client certificate not loaded.	N/A	Load a valid client certificate.	Information
Client certificate load successful.	Client certificate successfully loaded.	Information status message; press OK button to dismiss.	Information
Client certificate was not successfully loaded. Invalid certificate format.	Client certificate was not successfully loaded. Invalid certificate format.	Information status message; press OK button to dismiss.	Information
Client certificate was not successfully loaded. Outside of valid date range.	Client certificate load failed. Outside of valid date range.	Information status message; press OK button to dismiss.	Information
Synchronize successful.	Synchronize successful.	Information status message; press OK button to dismiss.	Information
Synchronize failed.	Synchronize failed.	Information status message; press OK button to dismiss.	Information

System messages

Condition	Cause	Remedy	Priority
Internal hardware failure.	Nurse call port failed to activate.	Internal malfunction. If the problem persists, check cable connections. If the problem is still present, perform functional checks for the host. If the problem is still present, replace main board and nurse call relay.	High
The scanner is not properly configured.	Barcode/RFID scanner is not configured as expected for Single Sign-on.	Device software detects a JadaK HS1R scanner attached and the scan data received does not have the correct identifiers then this alert is triggered. Reconfigure the Scanners for Single Sign on.	Very Low
	System failure	Press and hold the power button or remove the AC power and battery to reboot the monitor.	N/A
000000	System failure	Restart the monitor	N/A
Device is operating in battery mode.	Operating on Battery Mode	AC power cord has been disconnected	Information

Technical alarm and information messages

Condition	Cause	Remedy	Priority
Sleep mode is unavailable. Intervals monitoring is in progress.	Sleep mode is not allowed when intervals are in progress.	Stop any active intervals.	Information
Sleep mode is unavailable. An alarm is active.	Sleep mode is not allowed when alarms are active.	Clear all active alarms.	Information
Internal hardware failure.	The root file system is corrupted; restart not possible	Restart the monitor. If the problem persists, replace the main PCBA.	N/A
Internal hardware failure.	SPL memory test failure, the monitor will sound an SOS pattern	Restart the monitor. If the problem persists, replace the main PCBA.	N/A
Internal hardware failure. 1C1000	The monitor PIC communications never starts or quits. The communication won't reasonably recover at startup or during operation	Restart the monitor. If the problem persists, replace the main PCBA.	N/A
Low battery 30 minutes or less remaining. 1C1005	The battery power is low	Connect the power supply to AC power to charge the monitor.	Very low
Low battery 5 minutes or less remaining. 1C1006	The battery power is extremely low	Connect the power supply to AC power to charge the monitor.	High
Battery is critically low; plug into outlet. Device is shutting down. 1C1007	The battery power is critically low	Connect the power supply to AC power to charge the monitor.	High
Update unsuccessful. Reboot and retry. 1C1008	The software update failed	Restart the monitor. If the problem is still present, replace the main PCBA.	Very low
Host battery not charging. 1C100A	The host battery is not charging	Restart the monitor. If the problem is still present, check cable connections. If the problem is still present, perform functional checks for host. If the problem is still present, replace battery. If the problem persists, replace the main PCBA.	Very low
Factory default settings now active. 3A0001	The factory configuration settings are active	The monitor has been configured to factory defaults, any user settings have been reset.	Very low

Condition	Cause	Remedy	Priority
Unable to read configuration from USB. 3A0002	Unable to load file from the external USB memory device.	Retry the USB connection. If the problem is still present, check for a proper format of the USB drive. If the problem is still present, replace the USB device. If the problem persists, replace the main PCBA.	Very low
Internal hardware failure. Device will shut down. 1C100D	Power supply issue. The PMIC is too hot	Check the operating environment temperature. Allow the monitor to cool down before operating again. If the problem is still present, check the cable connections. If the problem is still present, perform functional checks for host. If the problem is still present, replace the battery. If the problem is still present, replace the main PCBA.	High
Unexpected restart occurred. 1C1012	The monitor unexpectedly restarted	Continue normal operation	High
Audio system not functional 1D0100	The speaker or audio code is faulty	Replace speaker. If the problem is still present, replace the main PCBA.	High
Connex 360 battery is not installed. 1C100E	There is no battery in the monitor	Check the monitor for a battery and install one if it is missing. If the problem is still present, perform diagnostic checks on the monitor. If the problem persists, replace the main PCBA.	Very low
No valid files found	No valid files were found on the USB flash drive	Re-insert the USB flash drive with valid files.	Information
Firmware update successful.	The software successfully updated	Information status message; press OK button to dismiss.	Information
Audio alarms are off.	The monitor alarm audio is off	Information status message; press OK button to dismiss.	Information
Advanced settings unavailable.	The advanced settings are unavailable because the monitor is not in an idle state	Confirm that no sensors are attached to the monitor, no alarms are active, and there is no unsaved data.	Information
USB accessory disconnected.	The USB device was disconnected from the monitor	Information status message; press OK button to dismiss	Information

Technical alarm and information messages

Condition	Cause	Remedy	Priority
Advanced settings	The Advanced settings code was entered correctly	Information status message; Exit Advanced settings to dismiss.	Information
Save not successful.	The device configuration or logs were not saved to the USB device	Information status message; press OK button to dismiss	Information
Save successful.	The device configuration or logs were saved to the USB device	Information status message; press OK button to dismiss	Information
Factory reset failed. Custom configuration file not deleted.	The monitor factory reset has failed.	Information status message; Exit Advanced settings to dismiss.	Information
Configuration upload successful.	The device configuration has successfully uploaded	Information status message; press OK button to dismiss	Information
Unable to load configuration.	The device configuration was not successfully uploaded	N/A	Information

Software update messages

Condition	Cause	Remedy	Priority
Software Update: Installation failed. Reboot and retry.	Failure to install subsystem	Restart the monitor.	Information
Software Update: Manager internal error	Software update manager internal error	Information status message; click OK button to dismiss.	Information

Specifications

Physical specifications

Protection classifications, all monitor configurations

Characteristic	Specification
Electrical rating	Input: 100 – 240 V AC, 50/60 Hz, 1.5 A Output: 15 V DC, 4.33 A , 65 W MAX
Duty cycle	Continuous operation
Type of protection against electric shock	Class I external power supply
Degree of protection against electric shock, for parts applied to patients	Type BF defibrillator proof IEC EN 60601-1, 2nd and 3rd Editions
Recovery time following defibrillator discharge	Less than or equal to 15 seconds
Flammable anesthetics	 WARNING Not suitable for use with flammable anesthetics.
Degree of protection provided by the enclosure with respect to harmful ingress of liquids	IP22 protection against vertically falling water drops when enclosure tilted up to 15°
Degree of protection provided by the enclosure with respect to harmful ingress of solid objects	IP22 protection against ingress of solid objects > 12.5mm in diameter
Height	Standard chassis: 9.43 in. (239.4 mm)
Width	Standard chassis: 15.96 in. (405.5 mm)
Depth	Standard chassis: 6.07 in. (154.3 mm)
Weight (including battery)	Standard chassis with SureTemp : 12 lb 5.44 kg

Graphical display resolution

Characteristic	Specification
Dimensional outline	12.5 in. (W) x 8.7 in. (H) x 0.65 in. (D) (318.50 mm [W] x 221.70 mm [H] x 16.6 mm [D])
Active area	10.32 in. (W) x 6.46 in. (H) (262.12 mm [W] x 164.20 mm [H])
Resolution	1280 x 800 pixels
Pixel arrangement	RGB (red, green, blue)
Pixel pitch (mm)	0.204 x 0.204
Color depth	16.7 M

Speaker volume

See *Alarm signals sound pressure levels* table, which follows.

Alarm and pulse tones, per IEC 60601-1-8

Characteristic	Specification
Pulse frequency (f_0)	high priority alarm - 1.4 Hz and 2.8 Hz duty cycle of 20-60% medium priority alarm - 0.4 Hz and 0.8 Hz duty cycle of 20-60%
Number of harmonic components in the range 300 Hz to 4000 Hz	minimum of 4
Effective pulse duration (t_d)	high priority: 75 – 200 ms medium and low priority: 125 – 250 ms
Rise time (t_r)	10 – 20% of t_d
Fall time ¹ (t_f)	$t_f < t_s - t_r$



NOTE The range of the relative sound pressure level of the harmonic components should be between a minimum of at least 53 dBA and a maximum of at least 80 dBA at the pulse frequency.

¹ Prevents overlap of pulses

Alarm signals sound pressure levels

Volume Settings	Very Low Priority Alarm	Low Priority Alarm	Medium Priority Alarm	High Priority Alarm
Low	55 ± 6 dBA	55 ± 6 dBA	55 ± 6 dBA	6 - 12 dBA greater than medium priority alarm at low volume
Medium	1 - 10 dBA greater than very low priority alarm at low volume	1 - 10 dBA greater than low priority alarm at low volume	1 - 10 dBA greater than medium priority alarm at low volume	6 - 12 dBA greater than medium priority alarm at medium volume
High	1 - 5 dBA greater than very low priority alarm at medium volume	1 - 5 dBA greater than low priority alarm at medium volume	1 - 5 dBA greater than medium priority alarm at medium volume	6 - 12 dBA greater than medium priority alarm at high volume



NOTE Measurement radius: 1.0 meter

Battery specifications

Battery specifications ¹	9 Cell
Composition	Lithium-ion
Age to 70% capacity ¹	300
Charge time to 100% capacity	6 hr

¹ After this many full charge and discharge cycles, the battery has aged to where its total capacity has been reduced to 70% of its rating.

Mobile stand specifications

Mobile stand	Per bin maximum weight limit	Total bins maximum weight limit	Mobile stand maximum weight limit
9000-C360	Front Bins (left and right: 1.0 lb/0.45 kg) Front Bin (middle: 3.0 lb/1.36 kg) Rear Bin: 3.0 lb/1.36 kg	8.0 lb /3.63 kg	48.3 lb /22.06 kg

Nurse Call connection specifications

Nurse Call	24V at 500mA maximum
------------	----------------------

NIBP specifications

NIBP specifications

Cuff pressure range	Meets or exceeds IEC 80601-2-30 standards for cuff pressure range
Systolic range	Adult: 30 to 260 mmHg (StepBP, SureBP) Pediatric: 30 to 260 mmHg (StepBP, SureBP) Neonate: 20 to 120 mmHg (StepBP)
Diastolic range	Adult: 20 to 220 mmHg (StepBP, SureBP) Pediatric: 20 to 220 mmHg (StepBP, SureBP) Neonate: 10 to 110 mmHg (StepBP)
Cuff Inflation Target	Adult: 160 mmHg (StepBP) Pediatric: 140 mmHg (StepBP) Neonate: 90 mmHg (StepBP)

Specifications

Maximum Target Pressure	Adult: 300 mmHg (StepBP, SureBP)
	Pediatric: 300 mmHg (StepBP, SureBP)
	Neonate: 130 mmHg (StepBP)
Blood pressure determination time	Typical: 15 seconds
	Maximum: 150 seconds
Blood pressure accuracy	Meets or exceeds ANSI/AAMI/ ISO 81060-2:2019 standards for noninvasive blood pressure accuracy (± 5 mmHg mean error, 8 mmHg standard deviation)
Mean Arterial Pressure (MAP) range The formula used to calculate MAP yields an approximate value.	Adult: 23 to 230 mmHg (StepBP, SureBP)
	Pediatric: 23 to 230 mmHg (StepBP, SureBP)
	Neonate: 13 to 110 mmHg (StepBP)
Pulse rate range (using blood pressure determination)	Adult: 30 to 200 bpm (StepBP, SureBP)
	Pediatric: 30 to 200 bpm (StepBP, SureBP)
	Neonate: 35 to 220 bpm (StepBP)
Pulse rate accuracy (using blood pressure determination)	$\pm 5.0\%$ (± 3 bpm)
Overpressure cutoff	Adult: 300 mmHg ± 15 mmHg
	Pediatric: 300 mmHg ± 15 mmHg
	Neonate: 150 mmHg maximum



NOTE The **Connex 360** monitor provides single-fault tolerant circuitry listed in IEC 80601-2-30 for NIBP modes and programs. It does not support the self-measurement mode section of the IEC standard.

SureTemp Plus temperature module specifications

SURETEMP PLUS temperature range	Calibration accuracy
26.7 °C to less than 35.8 °C	± 0.3 °C (Direct mode)
35.8 °C to less than 37.0 °C	± 0.2 °C (Direct mode)
37.0 °C to 39.0 °C	± 0.1 °C (Direct mode)
Greater than 39.0 °C to 41.0 °C	± 0.2 °C (Direct mode)
Greater than 41.0 °C to 43.3 °C	± 0.3 °C (Direct mode)
80.0 °F to less than 96.4 °F	± 0.5 °F (Direct mode)
96.4 °F to less than 98.0 °F	± 0.3 °F (Direct mode)
98.0 °F to 102.0 °F	± 0.2 °F (Direct mode)
Greater than 102.0 °F to 106.0 °F	± 0.3 °F (Direct mode)

SURETEMP PLUS temperature range	Calibration accuracy
Greater than 106.0 °F to 110.0 °F	±0.5 °F (Direct mode)

Direct Mode stabilization time

Oral and rectal	Axillary
Until the temperature stabilizes or 3 minutes	Until the temperature stabilizes or 5 minutes

Transient response time

Heating	Cooling
10.8 seconds	11.5 seconds

 **NOTE** Per 80601-2-56 clause 201.101.3

SURETEMP PLUS Predictive Mode	Clinical Bias (°C)	Limit of Agreement (°C)	Clinical Repeatability (°C)
Oral	-0.3 – 0.3	≤1.0	≤ 0.3
Rectal	-0.3 – 0.3	≤1.0	≤ 0.3
Pediatric Axillary	-0.3 – 0.3	≤1.0	≤ 0.3
Adult Axillary	-0.3 – 0.3	≤1.0	≤ 0.3

SpO₂ specifications

Refer to sensor manufacturer's instructions for use for additional information.

 **NOTE** Functional testers cannot be used to assess the accuracy of a pulse oximeter monitor.

While functional testers may be useful for verifying that the pulse oximeter sensor, cabling, and monitor are functional, they are incapable of providing the data required to properly evaluate the accuracy of a system's SpO₂ measurements. Fully evaluating the accuracy of the SpO₂ measurements requires, at a minimum, accommodating the wavelength characteristics of the sensor and reproducing the complex optical interaction of the sensor and the patient's tissue. These capabilities are beyond the scope of known bench-top testers. SpO₂ measurement accuracy can only be evaluated in vivo by comparing pulse oximeter readings with SaO₂ measurements obtained from simultaneously sampled arterial blood made using a laboratory CO-oximeter.



 **NOTE** Contact the sensor manufacturer for further SpO₂ clinical testing information.

 **NOTE** Refer to sensor manufacturer's instructions for use for further accuracy information.

 **NOTE** This information might be useful to clinicians, such as those performing photodynamic therapy. For Masimo, the range of the peak wavelengths and maximum optical output power of the light emitted by the SpO₂ probe is approximately 500 nm to approximately 1000 nm. The maximum radiant power of the strongest light is less than or equal to 25 mW.

Specifications

For Nellcor, the range of the peak wavelengths and maximum optical output power of the light emitted by the SpO2 probe is approximately 660 nm, to approximately 900 nm. The total optical output power of the sensor LEDs is less than 15 mW.

SpO2 specifications (Masimo specifications^{1 2 3 4 5 6 7})	
SpO2 performance measurement range	1 to 100%
Masimo SpO2 <i>specifications</i>	Accuracy specified when used with Masimo SET pulse oximetry monitors or with licensed Masimo SET pulse oximetry modules using PC series patient cables, during no motion. Numbers present ± 1 standard deviation. Plus or minus one standard deviation represents 68% of the population.
Masimo SpO2, No Motion	60 – 80 $\pm 3\%$, adults/pediatrics/infants 70 – 100 $\pm 2\%$, adults/pediatrics/infants; $\pm 3\%$, neonates
Masimo SpO2, Motion	70 – 100 $\pm 3\%$, adults/pediatrics/infants/neonates
Masimo SpO2, Low perfusion	70 – 100 $\pm 2\%$, adults/pediatrics/infants/neonates
Perfusion	0.02 % to 20 %
Masimo pulse rate , No Motion	25 – 240 ± 3 bpm, adults/pediatrics/infants/neonates
Masimo pulse rate, Motion	25 – 240 ± 5 bpm, adults/pediatrics/infants/neonates
Masimo pulse rate, Low perfusion	25 – 240 ± 3 bpm, adults/pediatrics/infants/neonates
Pulse rate	25 to 240 beats per minute (bpm) No motion: ± 3 digits Motion: ± 5 digits
Saturation	60% to 70%
 NOTE Saturation accuracy varies by sensor type. Refer to the sensor Instructions for use for additional accuracy information.	Adults, Neonates: ± 3 digits
Masimo <i>respiration rate specifications</i>	4 to 70 respirations per minute (rpm), 3 RPM ARMS 1 RPM Mean Error Adult and pediatric patients
Pulse rate	25 to 240 beats per minute (bpm) ± 3 digits (no motion)
Saturation	70% to 100%
 NOTE Saturation accuracy varies by sensor type.	Adult, neonate: ± 3 digits Low Perfusion: 0.02 % to 20 % ± 2 digits
Detected pulse rate	20 to 250 beats per minute (bpm) ± 3 digits
¹ SpO2, accuracy was determined by testing on healthy adult volunteers in the range of 60-100% SpO2 against a laboratory pulse oximeter. SpO2 accuracy was determined on 16 neonatal NICU patients ranging	

SpO2 specifications (Masimo specifications^{1 2 3 4 5 6 7})

- in age from 7-135 days old and weighing between 0.5-4.25 kg. Seventy-nine (79) data samples were collected over a range of 70-100% SaO₂ with a resultant accuracy of 2.9% SpO₂.
- 2 The Masimo sensors have been validated for no motion accuracy in human blood studies on healthy adult male and female volunteers with light to dark skin pigmentation in induced hypoxia studies in the range of 70-100% SpO₂ against a laboratory pulse oximeter and ECG monitor. This variation equals plus or minus one standard deviation. Plus or minus one standard deviation encompasses 68% of the population.
 - 3 The Masimo sensors have been validated for motion accuracy in human blood studies on healthy adult male and female volunteers with light to dark skin pigmentation in induced hypoxia studies in the range of 70-100% SpO₂ against a laboratory CO-oximeter and ECG monitor. This variation equals plus or minus one standard deviation which encompasses 68% of the population.
 - 4 The Masimo **SET** Technology has been validated for low perfusion accuracy in bench top testing against a BioTek Index 2 simulator and the Masimo simulator with signal strengths of greater than 0.02% and transmission of greater than 5% for saturations ranging from 70–100%. This variation equals plus or minus one standard deviation which encompasses 68% of the population.
 - 5 The Masimo sensors have been validated for pulse rate accuracy for the range of 25-240 bpm in bench top testing against a BioTek Index 2 simulator. This variation equals plus or minus one standard deviation which encompasses 68% of the population.
 - 6 The following substances may interfere with pulse oximetry measurements:
 - Elevated levels of Methemoglobin (MetHb) may lead to inaccurate SpO₂ measurements
 - Elevated levels of Carboxyhemoglobin (COHb) may lead to inaccurate SpO₂ measurements
 - Severe anemia may cause erroneous SpO₂ readings
 - Dyes, or any substance containing dyes, that change usual blood pigmentation may cause erroneous readings
 - Elevated levels of total bilirubin may lead to inaccurate SpO₂ reading
 - 7 Because Masimo measurements are statistically distributed, only about two-thirds of Masimo measurements can be expected to fall within \pm Arms of the value measured by a CO-OXIMETER.
-

SpO2 specifications (Nellcor specifications)^{1 2}

Nellcor sensor accuracy guide^{1 2 3}

SpO₂ measurement accuracy can only be evaluated in vivo by comparing pulse oximeter readings with SpO₂ measurements obtained from simultaneously sampled arterial blood made using a laboratory CO-oximeter. SpO₂ accuracy was validated through breathe-down-equivalent testing by Covidien using electronic measurements to prove equivalence to the Nellcor **N-600x** predicate device. The Nellcor **N-600x** predicate device was validated by performing human-subject, “breathe-down” clinical trials.

- 1 Some models of commercially available bench-top functional testers and patient simulators can be used to verify the proper functionality of Nellcor pulse oximeter sensors, cables and monitors. See the individual testing device's operator's directions for use for the procedures specific to the model of tester being used.
 - 2 Many functional testers and patient simulators have been designed to interface with the pulse oximeter's expected calibration curves and may be suitable for use with Nellcor monitors and/or sensors. Not all such devices, however, are adapted for use with the Nellcor **OxiMax** digital calibration system. While this will not affect use of the simulator for verifying system functionality, displayed SpO₂ measurement values may differ from the setting of the test device. For a properly functioning monitor, this difference will be reproducible over time and from monitor to monitor within the performance specifications of the test device.
-

SpO2 specifications (Nellcor specifications)^{1 2}

³ Because Nellcor measurements are statistically distributed, only about two-thirds of Nellcor measurements can be expected to fall within \pm Arms of the value measured by a co-oximeter.

Nellcor Sensor and Oximetry specifications

Characteristic	Specification
SpO2 performance measurement range	1% to 100%
Perfusion range	0.03% to 20%

Sensor Type	Patient Type	Specification	Accuracy
DS-100A	Adult (>40 kg)	70% to 100%	\pm 3 digits
OXI-A/N	Neonatal (<3kg)	70% to 100%	\pm 4 digits
	Adult (>40kg)	70% to 100%	\pm 3 digits
OXI-P/I	Pediatric/Infant (3 to 40kg)	70% to 100%	\pm 3 digits
D-YSE	Adult/ Pediatric (>30kg)	70% to 100%	\pm 3.5 digits
D-YSPD	Pediatric/Infant (3 to 40kg)	70% to 100%	\pm 3.5 digits
D-YS	Infant to adult (\geq 1kg)	70% to 100%	\pm 3 digits
	Neonatal (<1kg)	70% to 100%	\pm 4 digits
MAX-AI (MAX-A)	Adult (>40kg)	70% to 100%	No Motion: \pm 2 digits
	Pediatric (10 to 50 kg)	70% to 100%	Motion: \pm 3 digits
	Infant (3 to 20 kg)	70% to 100%	Low Perfusion: \pm 2 digits
		60% to 80%	\pm 3 digits
MAX-PI (MAX-P)	Adult (>40kg)	70% to 100%	No Motion: \pm 2 digits
	Pediatric (10 to 50 kg)	70% to 100%	Motion: \pm 3 digits
	Infant (3 to 20 kg)	70% to 100%	Low Perfusion: \pm 2 digits
		60% to 80%	\pm 3 digits
MAX-II (MAX-I)	Adult (>40kg)	70% to 100%	No Motion: \pm 2 digits
	Pediatric (10 to 50 kg)	70% to 100%	Motion: \pm 3 digits
	Infant (3 to 20 kg)	70% to 100%	Low Perfusion: \pm 2 digits
		60% to 80%	\pm 3 digits

Characteristic	Specification
Pulse rate unit of measure	Beats per minute
Pulse rate measurement range	20-250 beats per minute

Characteristic	Specification
Pulse rate accuracy	No Motion: ± 3 digits Motion: ± 5 digits Low Perfusion: ± 3 digits

Environmental specifications

Operating temperature	50 °F to 104 °F (10 °C to 40 °C)
Storage and transport temperature	-4 °F to 122 °F (-20 °C to 50 °C) for 30 days
Operating altitude and atmospheric pressure	-1250 to 10,000 ft (-381 m to 3,048 m) 70 kPa to 106 kPa
Storage and transport altitude and atmospheric pressure	-1250 to 18,300 ft (-381 m to 5,578 m) 50 kPa to 106 kPa for 1 day
Operating humidity	15% to 95% noncondensing
Storage and transport humidity	15% to 95% noncondensing for 30 days

Radio specifications

The monitor's radio operates on 802.11 networks.

Wireless network interface	IEEE 802.11 a/b/g/n/ac
Frequency	<i>2.4 GHz frequency bands</i> 2.4 GHz to 2.483 GHz <i>5 GHz frequency bands</i> 5.15 GHz to 5.35 GHz, 5.47 GHz to 5.725 GHz, and 5.725 GHz to 5.825 GHz
Channels	<i>2.4 GHz channels</i> 11 (3 non-overlapping) <i>5 GHz channels</i> 5.15 GHz to 5.35 GHz (Ch 36/40/44/48/52/56/60/64) 5.47 GHz to 5.725 GHz (Ch 100/104/108/112/116/120/124/128/132/136/140/144) 5.725 GHz to 5.825 GHz (Ch 149/153/157/161/165)
Encryption	Advanced Encryption Standard (AES CCM Algorithm), Encryption Key Provisioning, Static (40-bit and 128-bit lengths), Pre-Shared (PSK)
Dynamic encryption	EAP-TLS, EAP-TTLS, PEAP-GTC, PEAP-MSCHAPv2, PEAP-TLS
Antenna	FlexMIMO Dual-Band Flexible MIMO Antenna

Specifications

Wireless data rates	Support 802.11 ac/a/b/g/n 2X2 MIMO Mbps
	802.11b (DSSS, CCK) 1, 2, 5.5, 11 Mbps
	802.11a/g (OFDM) 6, 9, 12, 18, 24, 36, 48, 54 Mbps
	802.11n (OFDM, HT20/HT40, MCS 0-15)
	802.11ac (OFDM, HT20, MCS0-8; OFDM HT40/HT80, MCS 0-9)
Compliance	FCC Regulatory ID: SQG-SU60SOMC
	FCC Regulatory: 47 CFR FCC Part 15.247, 47 CFR FCC Part 15.407, 47 CFR FCC Part 2.1091, FCC Part 15 Subpart B Class B, AS/NZS Regulatory AS/NZS 2772.2:2011 AS/NZS 4268:2017, 62311:2008, EN 50665:2017, EN 50385:2017, EU 2015/863 (RoHS 3)
	Canada (ISED) Regulatory ID: 3147A-SU60SOMC Canada: ICES-003 ANSI C63.4:2014 RSS-102 RSS-247.
	<ul style="list-style-type: none">• TRNG: True random number generator• AES: 256-bit, 192-bit, 128-bit key algorithm, compliant with FIPS PUB 197 Specifications• TDES: Two-key or three-key algorithms, compliant with FIPS PUB 46-3 Specifications• Atmel/Microchip secure boot solution

WLAN TX power	802.11a	
	6 Mbps	18 dBm (63 mW)
	54 Mbps	16 dBm (40 mW)
	802.11b	
	1 Mbps	18 dBm (63 mW)
	11 Mbps	18 dBm (63 mW)
	802.11g	
	6 Mbps	18 dBm (63 mW)
	54 Mbps	16 dBm (40 mW)
	802.11n (2.4/5 GHz)	
	6.5 Mbps (MCS0-5/MCS8-13; HT20)	18 dBm (63 mW)
	65 Mbps (MCS6-7/MCS14-15; HT20)	16 dBm (40 mW)
	13.5 Mbps (MCS0-5/MCS8-13; HT40)	16 dBm (40 mW)
	135 Mbps (MCS6-7/MCS14-15; HT40)	14 dBm (25 mW)
	802.11ac (5 GHz)	
	6.5/13 Mbps (MCS0-6; Ntst=1,2; HT20)	18 dBm (63 mW)
	78/156 Mbps (MCS7-8; Ntst=1,2; HT20)	16 dBm (40 mW)
	13.5/27Mbps (MCS0-6; Ntst=1,2; HT40)	16 dBm (40 mW)
	180/360Mbps (MCS7-9; Ntst=1,2; HT40)	12 dBm (25 mW)
	29.3/58.5 Mbps (MCS0-5; Ntst=1,2; HT80)	14 dBm (25 mW)
263.3/526.5 Mbps (MCS6-8; Ntst=1,2; HT80)	12 dBm (15.8 mW)	
390/780 Mbps (MCS9; Ntst=1,2; HT80)	10 dBm (10 mW)	
Wi-Fi standards	IEEE 802.11a, 802.11b, 802.11d, 802.11e, 802.11g, 802.11h, 802.11i, 802.11n, 802.11r, 802.11ac, 802.11w, 802.11k, 802.11v	
WLAN security	WPA2-Personal, WPA2-Enterprise, WPA2-Enterprise Suite-B, WPA2-Enterprise Suite-B 192-bit, WPA3-Personal, WPA3-Personal transition, WPA3-Enterprise, WPA3-Enterprise transition, WPA3-Enterprise Suite-B, WPA3-Enterprise Suite-B 192-bit, and WPA3-OWE	
Dynamic 802.1X Extensible Authentication Protocol Types	EAP-TLS, EAP-TTLS, PEAP-GTC, PEAP-MSCHAPv2, PEAP-TLS	

To ensure compliance with local regulations, be sure the correct country in which the access point is installed is selected. This product can be used with the following restriction(s):

Norway - Does not apply for the geographical area within a radius of 20 km from the center of Ny-Ålesund.

France - Outdoor use is limited to 10 mW EIRP within the band 2454 to 2483.5 MHz.



NOTE Effective Isotropic Radiated Power (EIRP).



NOTE Some countries restrict the use of 5 GHz bands. The 802.11a radio in the monitor uses only the channels indicated by the access point with which the radio associates. The hospital IT department must configure access points to operate with approved domains.



NOTE For more information on radio specifications, please reference the *Wireless Best Practices Overview* by contacting Baxter Technical Support or visiting Baxter.com.

Configuration options



NOTE Some model numbers and product features described in this publication might not be available in your country. For the latest information about products and features, please contact Baxter Technical Support: Technical Support.



NOTE If options have been added to the device, the actual configuration will not match the model description.

The device has multiple configurations. Use the following table to determine model configurations. Not all configurations may be available. Model numbers include one item from each column.

Example

95MXT-B (North America)

See "Approved accessories" for power cord options available for each configuration.

Model	Parameter	
	SpO2	Temperature
95 = 9500 Wi-Fi ® + Ethernet series	C = Nellcor	T = SureTemp Plus
94 = 9400 Ethernet only series	M = Masimo	
	R = Masimo SpO2/RRp ¹	

¹ Contact Baxter Customer Care to purchase the optional respiration rate software license: 9000-RRP Masimo RRP C360 LICENSE

Model	Temperature	SpO2	NIBP	Connectivity
94CXT-B	SureTemp Plus	Nellcor	SureBP	Ethernet only
94MXT-B	SureTemp Plus	Masimo	SureBP	Ethernet only
94RXT-B	SureTemp Plus	Masimo with RRp	SureBP	Ethernet only
95CXT-B	SureTemp Plus	Nellcor	SureBP	Wi-Fi + Ethernet
95MXT-B	SureTemp Plus	Masimo	SureBP	Wi-Fi + Ethernet
95RXT-B	SureTemp Plus	Masimo with RRp	SureBP	Wi-Fi + Ethernet



NOTE For more information on radio specifications, please reference the *Wireless Best Practices Overview* by contacting Baxter Technical Support or visiting <https://baxter.com>.

Manufacture date: how to decode a serial number

The Serial number (SN) of a device reveals many details about its manufacture. The first four digits of the device SN reveal the device's location of manufacture and the last four digits indicate the date of manufacture.

SN: 1YYWW#####

where

YY = the 2-digit year

WW = the 2-digit year ISO week

is a sequential/incremental number that resets at the new year or when the value exceeds "999999".

Calibration

The device has no specific use time limitation. The device may remain in service until repair is required or operation indicates that it is out of calibration. However, if an error code appears on the device, stop using the device and have it inspected by a Baxter-certified technician.

Accuracy checks and calibration are only recommended if the device case is opened or if issues are suspected. In cases where the device case is opened or if issues are suspected, send the device in for repair.

Baxter recommends that a qualified service technician perform a full functional verification and calibration on an annual basis.

Specifications

Standards and compliance

General compliance and standards

The monitor complies with the following standards:

IEC 60601-1, IEC 60601-1-2, IEC 60601-1-6, IEC 60601-1-8, ISO 81060-2, IEC 80601-2-30, ISO 80601-2-56, ISO 80601-2-61, IEC 62366-1, IEC 62304, ISO 14971.

Country-specific standards are included in the applicable Declaration of Conformity.



Federal Communications Commission (FCC)

Federal Communication Commission Interference Statement

This equipment has been tested and found to comply with the limits for a Class B digital device, pursuant to Part 15 of the FCC Rules. These limits are designed to provide reasonable protection against harmful interference in a residential installation.

This equipment generates, uses, and can radiate radio frequency energy and, if not installed and used in accordance with the instructions, may cause harmful interference to radio communications. However, there is no guarantee that interference will not occur in a particular installation.

If this equipment does cause harmful interference to radio or television reception, which can be determined by turning the equipment off and on, the user is encouraged to try to correct the interference by one of the following measures:

1. Reorient or relocate the receiving antenna.
2. Increase the separation between the equipment and the receiver.
3. Connect the equipment into an outlet on a circuit different from that to which the receiver is connected.
4. Consult the dealer or an experienced radio/TV technician for help.

FCC CAUTION

Any changes or modifications not expressly approved by the party responsible for compliance could void the user's authority to operate this equipment.

This device complies with Part 15 of the FCC Rules. Operation is subject to the following two conditions:

1. This device may not cause harmful interference.
2. This device must accept any interference received, including interference that may cause undesired operation.

IMPORTANT NOTE FCC Radiation Exposure Statement

This equipment complies with FCC radiation exposure limits set forth for an uncontrolled environment. This equipment should be installed and operated with minimum distance 20 cm between the radiator and your body. This transmitter must not be co-located or operated in conjunction with any other antenna or transmitter.

ISED Canada statement

This device complies with ISED Canada's license-exempt RSSs. Operation is subject to the following two conditions:

1. This device may not cause interference.
2. This device must accept any interference, including interference that may cause undesired operation of the device.

This radio transmitter (IC: 3147A-SU60SOMC) has been approved by Industry Canada to operate with the antenna types listed below with the maximum permissible gain indicated.

Antenna types not included in this list, having a gain greater than the maximum gain indicated for that type, are strictly prohibited for use with this device.

Electrical Specifications		
Operating Frequency (MHz)	2400 - 2480	4900 - 5900
Peak Gain – Typ (dBi)	1.7	2.5
Peak Gain – Max (dBi)	2.0	3
VSWR Port 1 (Typ)	< 2.3:1	< 2.8:1
VSWR Port 2 (Typ)	< 2.3:1	< 2.8:1
VSWR (Max)	< 2.5:1	< 3.0:1
Isolation, dB (Typ)	> 19	> 19
Max Gain ±30 above Horizon (dBi)	N/A	2.2
Nominal Impedance (Ohms)	50	
Max Power @ 25 °C (Watts)	10	
Polarization	Linear H/V for each radiator	
Azimuth Beam Width	Omnidirectional	

CAUTION

Operations in the 5.25-5.35GHz band are restricted to indoor usage only.

Radiation Exposure Statement

This equipment complies with Canada radiation exposure limits set forth for an uncontrolled environment. This equipment should be installed and operated with minimum distance of 20 cm between the radiator and your body.

EMC compliance

Special precautions concerning electromagnetic compatibility (EMC) must be taken for all medical electrical equipment. This device complies with IEC 60601-1-2:2014/AMD1:2020 / EN 60601-1-2:2015/A1:2021.

- All medical electrical equipment must be installed and put into service in accordance with the EMC information provided in this Instructions for use.
- Portable and mobile RF communications equipment can affect the behavior of medical electrical equipment.

The monitor complies with all applicable and required standards for electromagnetic interference.

- It does not normally affect nearby equipment and devices.
- It is not normally affected by nearby equipment and devices.
- It is not safe to operate the monitor in the presence of high-frequency surgical equipment.
- However, it is good practice to avoid using the monitor in extremely close proximity to other equipment.



NOTE The monitor has essential performance requirements associated with blood pressure measurement, oxygen saturation, and temperature measurement. In the presence of EM disturbances, the device will display an error code. Once the EM disturbances stop the monitor will self-recover and perform as intended.



WARNING Use only Accessories recommended by Baxter for use with the monitor. Accessories not recommend by Baxter may affect the EMC emissions or immunity.



WARNING Maintain minimum separation distance of 12 inches (30 cm) between any part of the monitor and portable RF communication equipment (including peripherals such as antenna cables and external antennas). Performance of the monitor may be degraded if proper distance is not maintained.



CAUTION The use of the monitor adjacent to or stacked with other equipment or medical electrical systems should be avoided because it could result in improper operation. If such use is necessary, the monitor and other equipment should be observed to verify that they are operating normally.

Electromagnetic emissions

The monitor is intended for use in the electromagnetic environment specified below. The customer or user of the monitor should assure that it is used in such an environment.

Emissions test	Compliance	Electromagnetic environment - guidance
RF emissions CISPR 11	Group 1	The monitor uses RF energy only for its internal function. Therefore, its RF emissions are very low and are not likely to cause any interference in nearby electronic equipment.

Emissions test	Compliance	Electromagnetic environment - guidance
RF emissions CISPR 11	Class B	The monitor is suitable for use in all establishments, including domestic establishments and those directly connected to the public low voltage power supply network that supplies buildings used for domestic purposes.
Harmonic emissions IEC 61000-3-2	Class A	
Voltage fluctuations/ flicker emissions IEC 61000-3-3	Complies	

 **WARNING** This equipment/system is intended for use by healthcare professionals only. This equipment/ system may cause radio interference or may disrupt the operation of nearby equipment ¹. It may be necessary to take mitigation measures, such as re-orienting or relocating the monitor or shielding the location.

¹ The monitor contains a dual band 2.4 GHz and 5 GHz transmitter to facilitate wireless communication. The 5 GHz band supports orthogonal frequency-division multiplexing for **Wi-Fi** communication. The 2.4 GHz band supports orthogonal frequency-division multiplexing and direct sequencing spread spectrum for **Wi-Fi** communication. The 2.4 GHz band also supports frequency hopping spread-spectrum for **Bluetooth**[®] communication. The radio is operated according to the requirements of various agencies, including FCC 47 CFR 15.247 and Radio Equipment Directive 2014/53/EU. The transmitter is excluded from the EMC requirements of 60601-1-2, but should be considered when addressing possible interference issues between this and other devices.

Electromagnetic immunity

The monitor is intended for use in the electromagnetic environment specified below. The customer or the user of the monitor should assure that it is used in such an environment.

Immunity test	IEC 60601 test level	Compliance level	Electromagnetic environment - guidance
Electrostatic discharge (ESD) IEC 61000-4-2	±8 kV contact ±2 kV, ±4 kV, ±8 kV, ±15 kV air	±8 kV ±15 kV	Floors should be wood, concrete or ceramic tile. If floors are covered with synthetic material, the relative humidity should be at least 30%.
Electrical fast transient/ burst IEC 61000-4-4	±2 kV for power supply lines ±1 kV for input/ output lines	±2 kV ±1 kV	Mains power quality should be that of a typical commercial or hospital environment.
Surge IEC 61000-4-5	±0.5 kV, ±1 kV Line- to -line ±0.5 kV, ±1 kV, ±2 kV Line-to-ground	±1 kV ±2 kV	Mains power quality should be that of a typical commercial or hospital environment.

Immunity test	IEC 60601 test level	Compliance level	Electromagnetic environment - guidance
Voltage dips, short interruptions and voltage variations on power supply input lines IEC 61000-4-11	0 % U _T ; 0.5 cycle	0 % U _T ; 0.5 cycle	Mains power quality should be that of a typical commercial or hospital environment. If the user of the monitor requires continued operation during power mains interruptions, it is recommended that the monitor be powered from an uninterruptible power supply or a battery.
	At 0°, 45°, 90°, 135°, 180°, 225°, 270° and 315°	At 0°, 45°, 90°, 135°, 180°, 225°, 270° and 315°	
	0 % U _T ; 1 cycle	0 % U _T ; 1 cycle	
	70 % U _T ; 25/30 cycles Single phase: at 0°	70 % U _T ; 25/30 cycles	
	0 % U _T ; 250/300 cycle	0 % U _T ; 250/300 cycle	
Power frequency (50/60 Hz) magnetic field IEC 61000-4-8	30 A/m	30 A/m	Power frequency magnetic fields should be at levels characteristic of a typical location in a typical commercial or hospital environment.



NOTE U_T is the a.c. mains voltage prior to application of the test level.

Electromagnetic immunity table

The monitor is intended for use in the electromagnetic environment specified below. The customer or the user of the monitor should assure that it is used in such an environment.

Immunity test	IEC 60601 test level	Compliance level	Electromagnetic environment - guidance
			Portable and mobile RF communications equipment should be used no closer to any part of the monitor, including cables, than the recommended separation distance calculated from the equation applicable to the frequency of the transmitter.
			<i>Recommended separation distance</i>
Conducted RF IEC 61000-4-6	3 Vrms 150 kHz to 80 MHz	3 Vrms	$d = \left[\frac{3.5}{V_1} \right] \sqrt{P}$
	6 Vrms in ISM bands between 0.15 MHz and 80 MHz	6 Vrms	$d = \left[\frac{12}{V_2} \right] \sqrt{P}$

Immunity test	IEC 60601 test level	Compliance level	Electromagnetic environment - guidance
Radiated RF IEC 61000-4-3	3 V/m, 80 MHz to 2.7 GHz	3 V/m	$d = \left[\frac{23}{E_1} \right] \sqrt{P}$ 800 MHz to 2.7 GHz $d = \left[\frac{12}{E_1} \right] \sqrt{P}$ 80 MHz to 800 MHz where P is the maximum output power rating of the transmitter in watts (W) and d is the recommended separation distance in meters (m). Field strengths from fixed RF transmitters, as determined by an electromagnetic site survey ¹ , should be less than the compliance level in each frequency range ² . Interference may occur in the vicinity of equipment marked with the following symbol: <div style="text-align: center;">  </div>

¹ Field strengths from fixed transmitters, such as base stations for radio (cellular/cordless) telephones and land mobile radios, amateur radio, AM and FM radio broadcast, and TV broadcast cannot be predicted theoretically with accuracy. To assess the electromagnetic environment due to fixed RF transmitters, an electromagnetic site survey should be considered. If the measured field strength in the location in which the monitor is used exceeds the applicable RF compliance level above, the monitor should be observed to verify normal operation. If abnormal performance is observed, additional measures may be necessary, such as reorienting or relocating the monitor.

² Over the frequency range 150 kHz to 80 MHz, field strengths should be less than 3 V/m.



NOTE At 80 MHz and 800 MHz, the higher frequency range applies.



NOTE These guidelines may not apply in all situations. Electromagnetic propagation is affected by absorption and reflection from structures, objects, and people.

Test specifications for ENCLOSURE PORT IMMUNITY to proximity magnetic fields

Test frequency	Modulation	IMMUNITY TEST LEVEL (A/m)
134.2 kHz	Pulse modulation ¹ 2.1 kHz	65 ²
13.56 MHz	Pulse modulation ¹ 50 kHz	7.5 ²

¹ The carrier shall be modulated using a 50% duty cycle square wave signal.

² r.m.s. before modulation is applied

Recommended separation distances between portable and mobile RF communications equipment and the monitor

The monitor is intended for use in an electromagnetic environment in which radiated RF disturbances are controlled. The customer or user of the monitor can help prevent electromagnetic interference by maintaining a minimum distance between portable and mobile RF communications equipment (transmitters) and the monitor as recommended below, according to the maximum output power of the communications equipment.

Separation distance according to frequency of transmitter (m)				
Rated max. output power of transmitter (W)	150 kHz to 80 MHz outside ISM bands	150 kHz to 80 MHz in ISM bands	80 MHz to 800 MHz	800 MHz to 2.7 GHz
	$d = \left[\frac{3.5}{V_1}\right]\sqrt{P}$	$d = \left[\frac{12}{V_2}\right]\sqrt{P}$	$d = \left[\frac{12}{E_1}\right]\sqrt{P}$	$d = \left[\frac{23}{E_1}\right]\sqrt{P}$
0.01	0.12	0.20	0.12	0.23
0.1	0.37	0.63	0.38	0.73
1	1.17	2.00	1.20	2.30
10	3.69	6.32	3.79	7.27
100	11.67	20.00	12.00	23.00

For transmitters rated at a maximum output power not listed above, the recommended separation distance in meters (m) can be estimated using the equation applicable to the frequency of the transmitter, where P is the maximum output power rating of the transmitter in watts (W) according to the transmitter manufacturer.



NOTE At 80 MHz and 800 MHz, the separation distance for the higher frequency range applies.



NOTE These guidelines may not apply in all situations. Electromagnetic propagation is affected by absorption and reflection from structures, objects, and people.

Test specifications for enclosure port immunity to RF wireless communications equipment

Test frequency (MHz)	Band ¹ (MHz)	Service ¹	Modulation ²	Maximum power (W)	Distance (m)	Immunity test level (V/m)
385	380 - 390	TETRA 400	Pulse modulation ² 18 Hz	1.8	0.3	27
450	430 - 470	GMRS 460, FRS 460	FM ³ ±5 kHz deviation 1 kHz sine	2	0.3	28

Test frequency (MHz)	Band ¹ MHz	Service ¹	Modulation ²	Maximum power (W)	Distance (m)	Immunity test level (V/m)
710 745 780	704 - 787	LTE band 13, 17	Pulse modulation ² 217 Hz	0.2	0.3	9
810 870 930	800 - 960	GSM 800/900, TETRA 800, iDEN 820, CDMA 850, LTE Band 5	Pulse modulation ² 18 Hz	2	0.3	28
1720 1845 1970	1700 - 1990	GSM 1800; CDMA 1900; GSM 1900; DECT; LTE Band 1, 3, 4, 25; UMTS	Pulse modulation ² 217 Hz	2	0.3	28
2450	2400 - 2570	Bluetooth , WLAN, 802.11 b/g/n, RFID 2450, LTE Band 7	Pulse modulation ² 217 Hz	2	0.3	28
5240 5500 5785	5100 - 5800	WLAN 802.11 a/n	Pulse modulation ² 217 Hz	0.2	0.3	9

¹ For some services, only the uplink frequencies are included.

² The carrier shall be modulated using a 50 percent duty cycle square wave signal.

³ As an alternative to FM modulation, 50 percent pulse modulation at 18 Hz may be used because while it does not represent actual modulation, it would be worst case.

Appendix

Approved accessories

The following tables list approved monitor accessories and applied parts. For information about options, upgrades, and licenses, refer to the service manual.



WARNING Use only Baxter approved accessories and applied parts, and use them according to the manufacturer's directions for use. Using unapproved accessories with the monitor or applied parts can affect patient and operator safety and can compromise product performance and accuracy, and void the product warranty.

Accessories

Blood pressure accessories [not made with natural rubber latex]

Part number	Model	Description
4500-34	BP	Fast BP hose w Fport, 5 ft
4500-35	BP	Fast BP hose w Fport, 10 ft
7000-33	BP	Neonatal blood pressure hose (10 ft)
6000-30	BP	Single tube blood pressure hose (5 ft)
6000-31	BP	Single tube blood pressure hose (10 ft)

Mounting options

Part number	Description
9000-C360	Connex 360 monitor Mobile Stand
9000-GCX	Connex 360 monitor Wall Mount Kit

Miscellaneous items

Part number	Description
BATT99	Lithium-ion battery 9 Cell — Extended Life
PWCD-B	Line cord B, North America
6000-NC	Nurse call cable
6000-916HS	Jadak 2D Scanner
7000-916HS	Jadak 2D Scanner
6000-916HSR	Jadak 2D/HF RFID Scanner
7000-916HSR	Jadak 2D/HF RFID Scanner
7000-916HS 1RS	Jadak 2D/HF RFID Scanner

Part number	Description
7000-CS6080	Zebra 2D/HF RFID Scanner
9000-PS	Connex 360 Power Supply, External, 65W

Upgrade options

Part number	Description
108970	UPGD KIT-CNX360-ASSY SPO2 NELLCOR CONVERSION UPGRADE
108971	UPGD KIT-CNX360-ASSY SPO2 MASIMO CONVERSION UPGRADE
108873	SRV KIT-CNX360-WIRELESS RADIO PCBA-ANT

Applied parts

Blood pressure cuffs



NOTE Some model numbers and product features described in this publication might not be available in your country. For the latest information about products and features, contact Baxter Customer Care.

Blood pressure cuffs [not made with natural rubber latex]

Part Number	Model	Description
Neo-1-1	Disposable	Cuff, soft, NEO 1, 1-TUBE, NQ (box of 10)
Neo-2-1	Disposable	Cuff, soft, NEO 2, 1-TUBE, NQ (box of 10)
Neo-3-1	Disposable	Cuff, soft, NEO 3, 1-TUBE, NQ (box of 10)
Neo-4-1	Disposable	Cuff, soft, NEO 4, 1-TUBE, NQ (box of 10)
Neo-5-1	Disposable	Cuff, soft, NEO 5, 1-TUBE, NQ (box of 10)
REUSE-08	Reusable	Cuff, reusable, sm child
REUSE-09	Reusable	Cuff, reusable, child
REUSE-10	Reusable	Cuff, reusable, sm adult
REUSE-11	Reusable	Cuff, reusable, adult
REUSE-11L	Reusable	Cuff, reusable adult long
REUSE-12	Reusable	Cuff, reusable, lg adult
REUSE-12L	Reusable	Cuff, reusable, lg adult long
REUSE-13	Reusable	Cuff, reusable, thigh
SOFT-07	Disposable	Cuff, infant
SOFT-08	Disposable	Cuff, small child
SOFT-09	Disposable	Cuff, child
SOFT-10	Disposable	Cuff, small adult

Part Number	Model	Description
SOFT-11	Disposable	Cuff, adult
SOFT-11L	Disposable	Cuff, adult long
SOFT-12	Disposable	Cuff, lg adult
SOFT-12L	Disposable	Cuff, lg adult long
SOFT-13	Disposable	Cuff, thigh
ECOCUFF-09	Disposable	Cuff, child
ECOCUFF-10	Disposable	Cuff, small adult
ECOCUFF-11	Disposable	Cuff, adult
ECOCUFF-12	Disposable	Cuff, adult large

Masimo pulse oximetry

Baxter part number	Masimo part number	Description
LNCS-DCI	1863	Reusable finger sensor - Adult
LNCS-DCIP	1864	Reusable finger sensor - Pediatric
LNCS-ADTX	1859	Disposable adhesive finger sensor - Adult (20 per case)
LNCS-PDTX	1860	Disposable adhesive finger sensor - Pediatric (20 per case)
RED LNC-04	2055	4' Cable w/ MINID Connector
RED LNC-10	2056	10' Cable w/ MINID Connector
LNCS-YI	2258	Multisite reusable sensor (1 sensor, 6 adhesive wraps)
LNCS-TC-I	1895	Reusable ear sensor
LNCS-NEO-L-3	2320	Disposable adhesive finger sensor - Neonate/Adult (20 per case)
NEO-WRAP-RP	2308	Replacement wrap for neonatal adhesives (100 per case)
LNCS-INF-3	2319	Disposable adhesive finger sensor - Infant (20 per case)
INF-WRAP-RP	2307	Replacement wrap for infant adhesives (100 per case)
YI-AD	1597	Multisite adhesive wrap adult/pediatric/neonatal for YI sensor (100 per case)
YI-FM	1602	Multisite foam wrap adult/pediatric/neonatal for YI sensor (12 per case)
RDSETDCI	4050	Reusable finger sensor - Adult
RDSETDCIP	4051	Reusable finger sensor - Pediatric
RDSETADT	4000	Disposable adhesive finger sensor - Adult (20 per case)
RDSETPDT	4001	Disposable adhesive finger sensor - Pediatric (20 per case)
RDSETYI	4054	Multisite reusable sensor (1 sensor, 6 adhesive wraps)

Baxter part number	Masimo part number	Description
RDSETTCI	4053	Reusable ear sensor
RDSETNEO	4003	Disposable adhesive finger sensor - Neonate (20 per case)
RDSETINF	4002	Disposable adhesive finger sensor - Infant (20 per case)
RDSETDBI	4052	Adult Soft Sensor
RDSET5	4072	5' 20-Pin Patient Extension Cable with Sensor Connector
RDSET12	4073	12' 20-Pin Patient Extension Cable with Sensor Connector

Nellcor pulse oximetry

Part number	Model	Description
DS-100A	OxiMax	Durasensor adult oxygen transducer
DOC-10	OxiMax	Extension cable (10 feet)
DOC-4	OxiMax	Extension cable (4 feet)
OXI-A/N	OxiMax	Oxiband adult/neonatal transducer (1 sensor, 50 wraps)
OXI-P/I	OxiMax	Oxiband pediatric/infant transducer (1 sensor, 50 wraps)
D-YS	OxiMax	Dura-Y oxygen transducer (1 sensor, 40 wraps)
D-YSE	OxiMax	Ear clip (use with Dura-Y sensor)
D-YSPD	OxiMax	PediCheck pediatric spot check (use with Dura-Y sensor)
MAX-AI	OxiMax	Adult sensor (single use, case of 24)
MAX-A	OxiMax	Adult sensor (single use, case of 24)
MAX-PI	OxiMax	Pediatric sensor (single use, case of 24)
MAX-P	OxiMax	Pediatric sensor (single use, case of 24)
MAX-II	OxiMax	Infant sensor (single use, case of 24)
MAX-I	OxiMax	Infant sensor (single use, case of 24)

SureTemp Plus thermometry

Part number	Description
02895-000	Oral probe and well kit (9ft. / 2.7M)
02895-100	Rectal probe and well kit (9ft. / 2.7M)
02894-0000	Oral probe well (blue)
02894-1000	Rectal probe well (red)
05031-101	SureTemp Plus Disposable probe covers (1,000 covers, packaged 25/box)
05031-110	SureTemp Plus Disposable probe covers (10,000 covers, packaged 25/box)

Part number	Description
06138-000	Temperature calibration key
01802-110	9600 Plus calibration tester

Warranty

Welch Allyn warrants the product to be free of defects in material and workmanship and to perform in accordance with manufacturer's specifications for the period of two years from the date of purchase from Welch Allyn or its authorized distributors or agents.

The warranty period shall start on the date of purchase. The date of purchase is: 1) the invoiced ship date if the device was purchased directly from Welch Allyn, 2) the date specified during product registration, 3) the date of purchase of the product from a Welch Allyn authorized distributor as documented from a receipt from said distributor.

This warranty does not cover damage caused by 1) handling during shipping, 2) use or maintenance contrary to labeled instructions, 3) alteration or repair by anyone not authorized by Welch Allyn, and 4) accidents.

The product warranty is also subject to the following terms and limitations: Accessories are not covered by the warranty. Refer to the instructions for use provided with individual accessories for warranty information.

Shipping cost to return a device to a Welch Allyn Service center is not included.

A service notification number must be obtained from Welch Allyn prior to returning any products or accessories to Welch Allyn's designated service centers for repair. To obtain a service notification number, contact Welch Allyn Technical Support.

THIS WARRANTY IS IN LIEU OF ALL OTHER WARRANTIES, EXPRESS OR IMPLIED, INCLUDING BUT NOT LIMITED TO THE IMPLIED WARRANTIES OF MERCHANTABILITY AND FITNESS FOR A PARTICULAR PURPOSE. BAXTER'S OBLIGATION UNDER THIS WARRANTY IS LIMITED TO REPAIR OR REPLACEMENT OF PRODUCTS CONTAINING A DEFECT. BAXTER IS NOT RESPONSIBLE FOR ANY INDIRECT OR CONSEQUENTIAL DAMAGES RESULTING FROM A PRODUCT DEFECT COVERED BY THE WARRANTY.

Warranty

Baxter